

Name _____

Date _____

1. Fill in the blanks to make true statements.

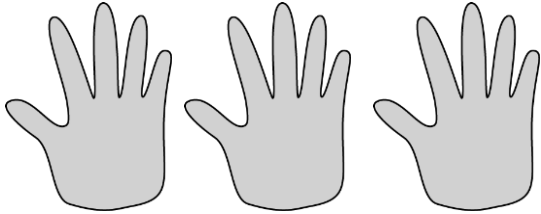

a. 3 groups of five = _____

3 fives = _____

$3 \times 5 =$ _____

b. $3 + 3 + 3 + 3 + 3 =$ _____

5 groups of three = _____

$5 \times 3 =$ _____

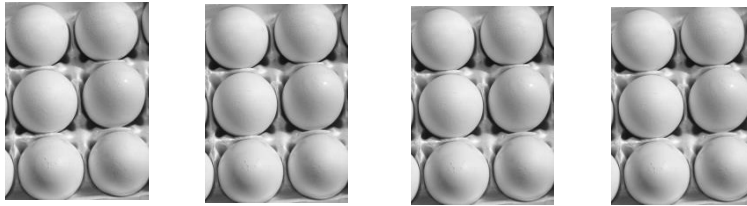

c. $6 + 6 + 6 + 6 =$ _____

_____ groups of six = _____

$4 \times$ _____ = _____



d. $4 +$ _____ $+$ _____ $+$ _____ $+$ _____ $+$ _____ $=$ _____

6 groups of _____ = _____

$6 \times$ _____ = _____

2. The picture below shows 2 groups of apples. Does the picture below show 2×3 ? Explain why or why not.

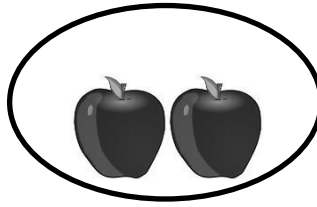
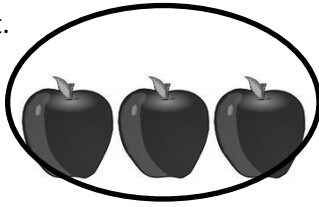

3. Draw a picture to show $2 \times 3 = 6$.

4. Caroline, Brian and Marta want to share a box of chocolates so that they each get the same amount. Circle the chocolates below to show 3 groups of 4. Then write addition and multiplication sentences to represent the problem.

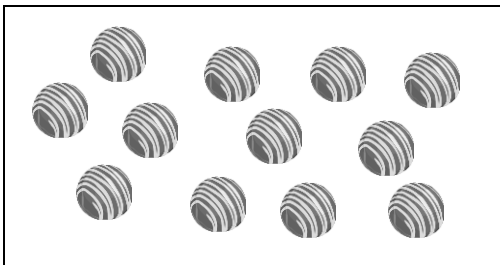

Name _____

Date _____

Use the arrays below to answer each set of questions.

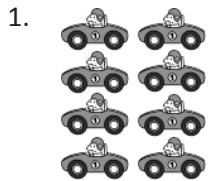

a. How many rows of cars are there? _____

b. How many cars are there in each row? _____

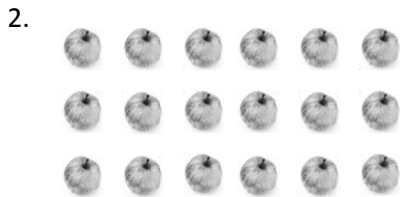

a. What is the number of rows? _____

b. What is the number of objects in each row? _____



a. There are 4 spoons in each row. How many spoons are in 2 rows? _____

b. Write a multiplication fact to describe the array. _____

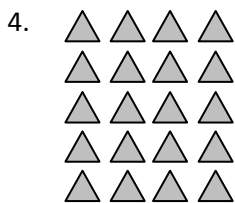

a. There are 5 rows of triangles. How many triangles are in each row? _____

b. Write a multiplication fact to describe the total number of triangles. _____

5. The dots below show 2 groups of 5.



a. Redraw the circles as an array that shows 2 rows of 5.



b. Compare the drawing to your array. Write at least 1 reason why they are the same and 1 reason why they are different.

6. Emma collects rocks. She arranges them in 4 rows of 3. Draw Emma's array to show how many rocks she has altogether. Then write a multiplication sentence to describe the array.

7. Joshua helps his father organize cans of food in the cupboard. He makes an array with the cans and thinks, "My cans show 5×3 !" Make a drawing that shows how many cans are in Joshua's array.

Name _____

Date _____

Solve numbers 1–4 using the pictures provided for each problem.

1. There are 5 flowers in each bunch. How many flowers are in 4 bunches?



a. Number of groups: _____ Size of each group: _____

b. $4 \times 5 =$ _____

c. There are _____ flowers altogether.

2. There are _____ candies in each box. How many candies are in 6 boxes?

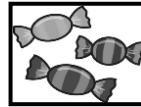
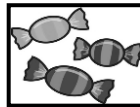
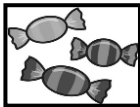

a. Number of groups: _____ Size of each group: _____

b. $6 \times$ _____ $=$ _____

c. There are _____ candies altogether.

3. There are 4 oranges in each row. How many oranges are there in _____ rows?

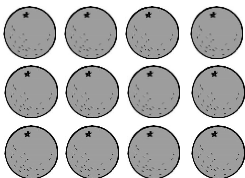

a. Number of rows: _____ Size of each row: _____

b. _____ $\times 4 =$ _____

c. There are _____ oranges altogether.

4. There are _____ loaves of bread in each row. How many loaves of bread are there in 5 rows?

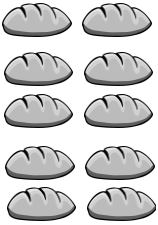

a. Number of rows: _____ Size of each row: _____

b. _____ × _____ = _____

c. There are _____ loaves of bread altogether.

5. a. Write a multiplication sentence for the array shown below.

X X X
 X X X
 X X X
 X X X

b. Draw a number bond for the array where each part represents the amount in one row.

6. Draw an array using factors 2 and 3. Then show a number bond where each part represents the amount in one row.

Name _____

Date _____

1.

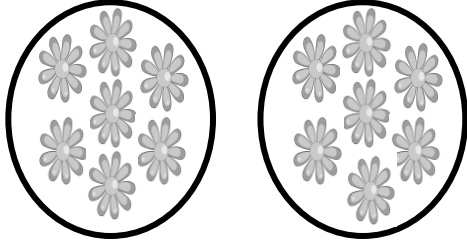

Divide 14 flowers into 2 equal groups.
There are _____ flowers in each group.

2.

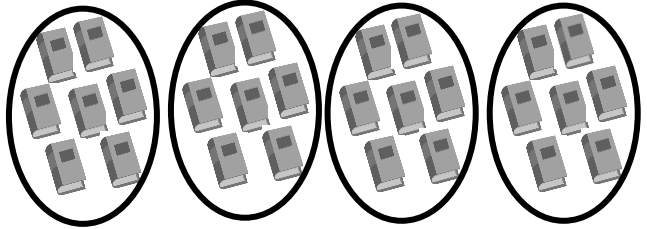

Divide 28 books into 4 equal groups.
There are _____ books in each group.

3.

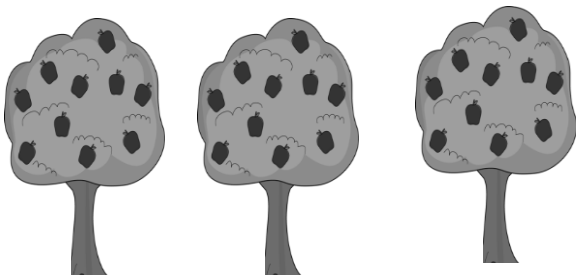

Divide 30 apples into _____ equal groups.
There are _____ apples in each group.

4.

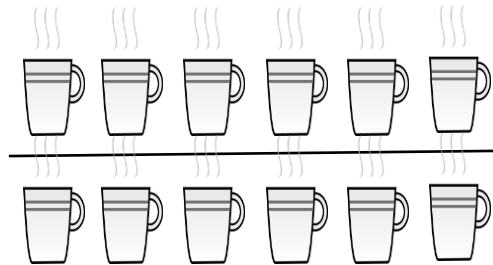

Divide _____ cups into _____ equal groups.
There are _____ cups in each group.
 $12 \div 2 = \underline{\hspace{2cm}}$

5.

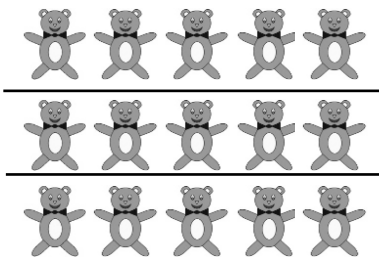

There are _____ toys in each group.
 $15 \div 3 = \underline{\hspace{2cm}}$

6.

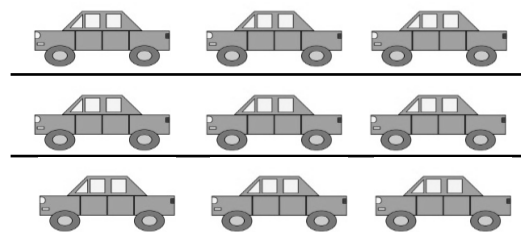

$9 \div 3 = \underline{\hspace{2cm}}$

7. Audrina has 24 colored pencils. She puts them in 4 equal groups. How many colored pencils are in each group?

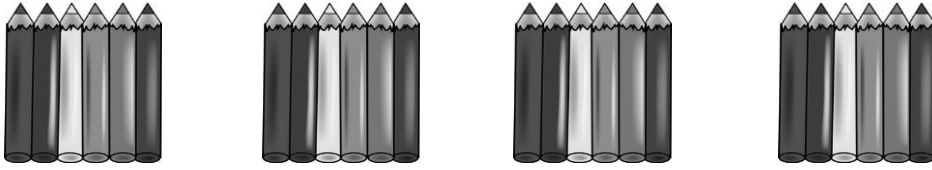

There are _____ colored pencils in each group.

$24 \div 4 = \underline{\hspace{2cm}}$

8. Charlie picks 20 apples. He divides them equally between 5 baskets. Draw the apples in each basket.



There are _____ apples in each basket.

$20 \div \underline{\hspace{2cm}} = \underline{\hspace{2cm}}$

9. Chelsea collects butterfly stickers. The picture shows how she placed them in her book. Write a division sentence to show how she equally grouped her stickers.

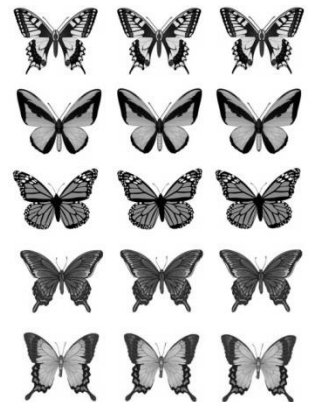

There are _____ butterflies in each row.

$\underline{\hspace{2cm}} \div \underline{\hspace{2cm}} = \underline{\hspace{2cm}}$

Name _____

Date _____

1.



Divide 6 tomatoes into groups of 3.

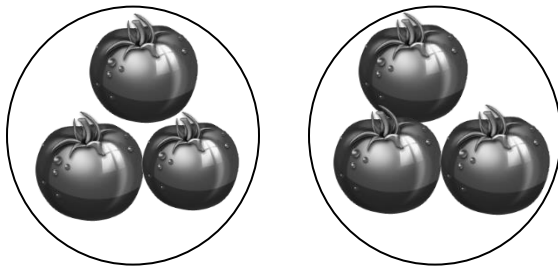

There are _____ groups of 3 tomatoes.

$6 \div 3 = 2$

2.



Divide 8 lollipops into groups of 2.

There are _____ groups.

$8 \div 2 = \underline{\hspace{2cm}}$

3.



Divide 10 stars into groups of 5.

$10 \div 5 = \underline{\hspace{2cm}}$

4.

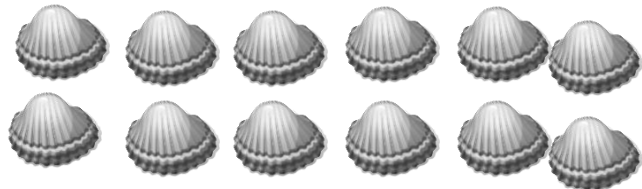

Divide the shells to show $12 \div 3 = \underline{\hspace{2cm}}$
where the unknown represents the number of groups.

How many groups are there? _____

5. Rachel has 9 crackers. She puts 3 crackers in each bag. Circle the crackers to show Rachel's bags.

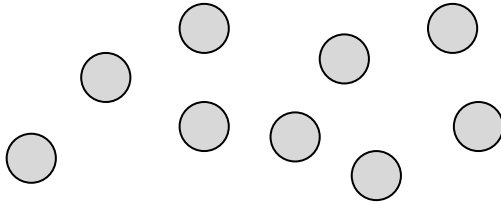

- a. Write a division sentence where the answer represents the number of Rachel's bags.
- b. Draw a number bond to show Rachel's crackers.
6. Jameisha has 16 wheels to make toy cars. She uses 4 wheels for 1 car.
- a. Use a count-by to find the number of cars Jameisha can build. Make a drawing to match your counting.
- b. Write a division sentence to represent the problem.

Name _____

Date _____

1. Rick puts 15 tennis balls into cans. Each can holds 3 balls. Circle groups of 3 to show the balls in each can.

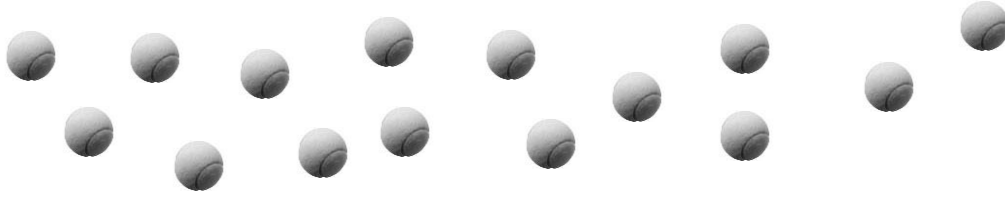

Rick needs _____ cans.

_____ \times 3 = 15

15 \div 3 = _____

2. Rick uses 15 tennis balls to make 5 equal groups. Draw to show how many tennis balls are in each group.

There are _____ tennis balls in each group.

5 \times _____ = 15

15 \div 5 = _____

3. Use an array to model Problem 1.

a) _____ \times 3 = 15

15 \div 3 = _____

The number in the blanks represents:

_____.

b) 5 \times _____ = 15

15 \div 5 = _____

The number in the blanks represents:

_____.

4. Deena makes 21 jars of tomato sauce on her farm. She puts 7 jars in each box to sell at the supermarket. How many boxes does Deena need?

$$21 \div 7 = \underline{\quad}$$

$$\underline{\quad} \times 7 = 21$$

What is the meaning of the unknown factor and quotient? _____

5. The teacher gives the problem $4 \times \underline{\quad} = 12$. Charlie finds the answer by writing and solving $12 \div 4 = \underline{\quad}$. Explain why Charlie's method works.

6. The blanks in Problem 5 represent the size of the groups. Draw an array to represent the number sentences.

Name _____

Date _____

1. a. Count by 2 six times.

_____, _____, _____, _____, _____, _____

b. Draw an array that matches your count-by.

c. Write a multiplication sentence that represents the total number of objects in your array.

_____ × _____ = _____

2. a. Count by 6 two times.

_____, _____

b. Draw an array that matches your count-by.

c. Write a multiplication sentence that represents the total number of objects in your array.

_____ × _____ = _____

3. a. Compare your work in Problems 1 and 2. Turn your paper as you study the arrays to look at them in different ways.

b. Why are the factors in your multiplication sentences in a different order?

4. Count by the unit (the number in word form) the number of times indicated. Write the multiplication sentence that matches your count by. The first one is done for you.

a. 6 twos: 6 × 2 = 12

d. 2 sevens: _____

Bonus Questions:

b. 2 sixes: _____

e. 9 twos: _____

g. 11 twos: _____

c. 7 twos: _____

f. 2 nines: _____

h. 2 twelves: _____

5. Write and solve a different multiplication sentence to describe each array.



6. Ms. Nenadal writes $2 \times 7 = 7 \times 2$ on the board. Do you agree or disagree? Draw arrays to help explain your thinking.

7. Find the missing factor to make each number sentence true.

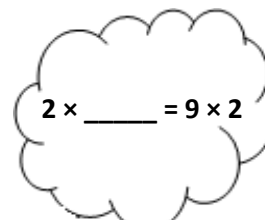
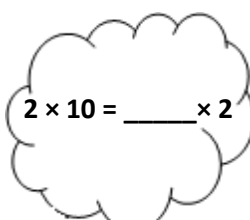
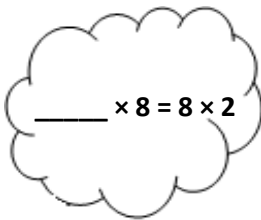
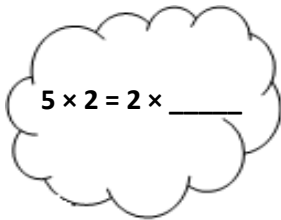

8. Jada gets 2 new packs of erasers. Each pack has 6 erasers in it.

a. Draw an array to show how many erasers Jada has altogether.

b. Write and solve a multiplication sentence to describe the array.

c. Use the commutative property to write and solve a different multiplication sentence for the array.

Name _____

Date _____

1. a. Count by 3 five times.

_____ / _____ / _____ / _____ / _____

b. Draw an array that matches your count-by.

2. a. Count by 5 three times.

_____ / _____ / _____

b. Draw an array that matches your count-by.

3. Write multiplication expressions below to represent your arrays in Problems 1 and 2. Use the commutative property to make the equation true.

$$\frac{\quad}{\text{Problem 1}} \times \frac{\quad}{\quad} = \frac{\quad}{\quad} \times \frac{\quad}{\text{Problem 2}}$$

4. Count by the unit (the number in word form) the number of times indicated. Write the multiplication sentence that matches your count by. The first one is done for you.

a. 2 threes: $2 \times 3 = 6$

d. 4 threes: _____

g. 3 nines: _____

b. 3 twos: _____

e. 3 sevens: _____

h. 9 threes: _____

c. 3 fours: _____

f. 7 threes: _____

i. 10 threes: _____

5. Find the unknowns that make the number sentences true. Then draw a line to match facts that are related.

a. $3 + 3 + 3 + 3 + 3 =$ _____

d. $3 \times 8 =$ _____

b. $3 \times 9 =$ _____

e. _____ $= 5 \times 3$

c. 7 threes + 1 three = _____

f. $27 = 9 \times$ _____

6. Isaac picks 3 tangerines from his tree every day for 7 days.
- Use circles to draw an array that represents the tangerines Isaac picks.
 - How many tangerines does Isaac pick in 7 days? Write and solve a multiplication sentence.
 - Isaac decides to pick 3 tangerines every day for 3 more days. Draw 'x's to show the new tangerines on the array in part A.
 - Write and solve a multiplication sentence to find the total number of tangerines Isaac picks.
7. Sarah buys bottles of soap. Each bottle costs \$2.
- How much money does Sarah spend if she buys 3 bottles of soap?

$$\underline{\hspace{2cm}} \times \underline{\hspace{2cm}} = \$ \underline{\hspace{2cm}}$$

- How much money does she spend if she buys 6 bottles of soap?

$$\underline{\hspace{2cm}} \times \underline{\hspace{2cm}} = \$ \underline{\hspace{2cm}}$$

Name _____

Date _____

1. The team organizes soccer balls into 2 rows of 5. The coach adds 3 rows of 5 soccer balls. Complete the number sentences to describe the total array.



a. $(5 + 5) + (5 + 5 + 5) =$ _____

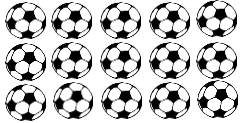

b. 2 fives + _____ fives = _____ fives

c. _____ $\times 5 =$ _____

2. $7 \times 2 =$ _____

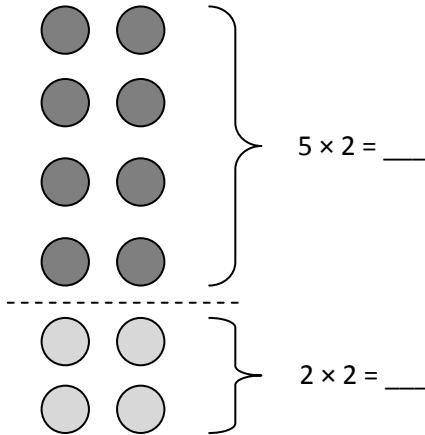

$10 + 4 =$ _____

_____ $\times 2 = 14$

3. $9 \times 2 =$ _____

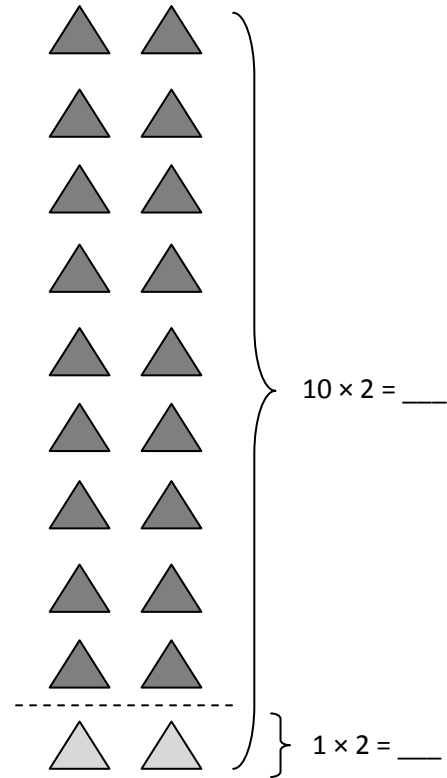

$20 -$ _____ $= 18$

$9 \times 2 =$ _____

4. Matthew organizes his baseball cards in 4 rows of 3.
- a. Draw an array that represents Matthew's cards using an x to show each card.

b. Solve the multiplication sentence to find Matthew's total number of cards. $4 \times 3 = \underline{\hspace{2cm}}$

5. Matthew adds 2 more rows. Use circles to show his new cards on the array in part 4a.

- a. Write and solve a multiplication sentence to represent the circles you added to the array.

$$\underline{\hspace{2cm}} \times 3 = \underline{\hspace{2cm}}$$

- b. Add the totals from the multiplication facts in 4b and 5a to find Matthew's total cards.

$$\underline{\hspace{2cm}} + \underline{\hspace{2cm}} = 18$$

- c. Write the multiplication sentence that shows Matthew's total number of cards.

$$\underline{\hspace{2cm}} \times \underline{\hspace{2cm}} = 18$$

Name _____

Date _____

1. $7 \times 3 = (5 \times 3) + (2 \times 3) =$ _____

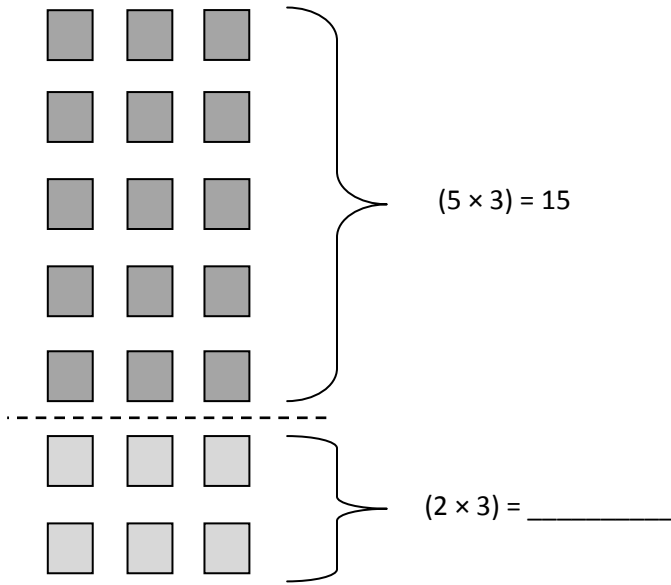

$(5 \times 3) + (2 \times 3) = 15 +$ _____

$15 +$ _____ $=$ _____

2. $8 \times 3 = (4 \times 3) + (4 \times 3) =$ _____

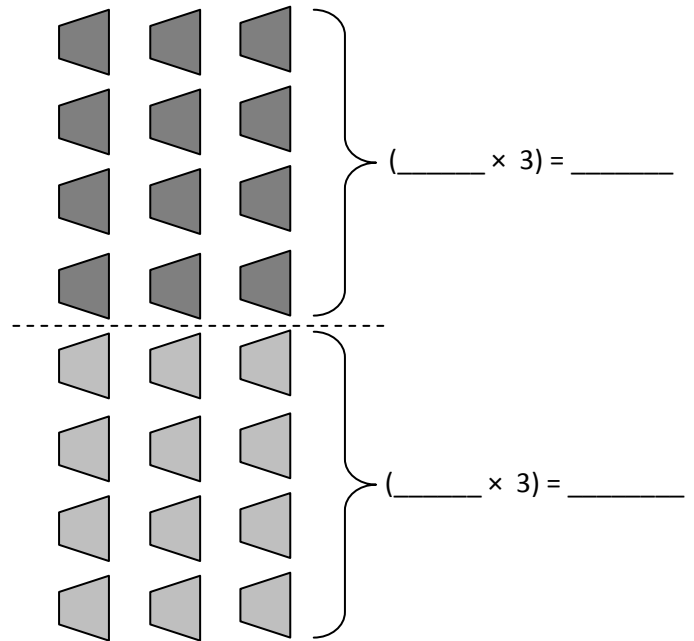

$(4 \times 3) + (4 \times 3) =$ _____ $+$ _____

_____ $\times 3 =$ _____

3. Ruby is making a photo album. She puts 3 pictures in each row.
- a. Use the multiplication sentences on the left. Draw arrays to show the photos on the upper and lower parts of Ruby’s album page.

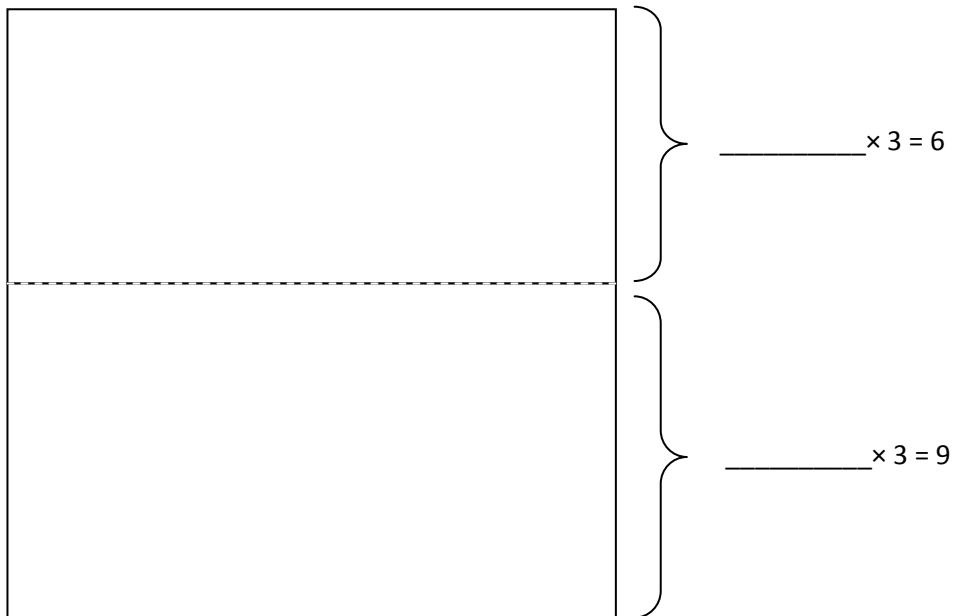

- b. Ruby calculates the total number of pictures as shown below. Use the array you drew to help explain her calculation.

$5 \times 3 = 6 + 9 = 15$

Name _____

Date _____

1. Mrs. Prescott has 12 oranges. She puts 2 oranges in each bag. How many bags does she have?

a. Draw an array where each column shows a bag of oranges.

$$\underline{\hspace{2cm}} \div 2 = \underline{\hspace{2cm}}$$

b. Redraw the oranges in each bag as a unit in the tape diagram. The first unit is done for you. As you draw, label the diagram with known and unknown information from the problem.

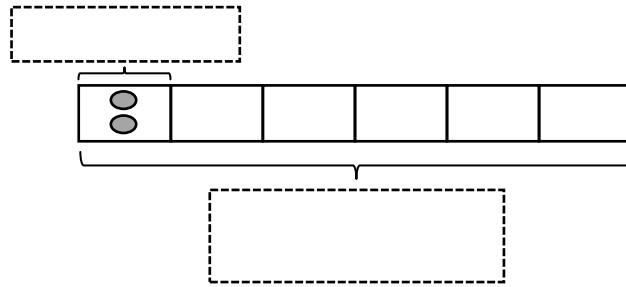

2. Mrs. Prescott arranges 18 plums into 6 bags. How many plums are in each bag? Model the problem with both an array and a labeled tape diagram. Show each column as the number of plums in each bag.

There are _____ plums in each bag.

3. Fourteen shopping baskets are stacked equally in 7 piles. How many baskets are in each pile? Model the problem with both an array and a labeled tape diagram. Show each column as the number of baskets in each pile.
4. In the back of the store, Mr. Prescott packs 24 bell peppers equally into 8 bags. How many bell peppers are in each bag? Model the problem with both an array and a labeled tape diagram. Show each column as the number of bell peppers in each bag.
5. Olga saves \$2 a week to buy a toy car. The car costs \$16. How many weeks will it take her to save enough to buy the toy?

Name _____

Date _____

Name _____

Date _____

1. There are 8 birds at the pet store. 2 birds are in each cage. Circle to show how many cages there are.



$8 \div 2 = \underline{\hspace{2cm}}$

There are _____ cages of birds.

2. The pet store sells 10 fish. They equally divide the fish into 5 bowls. Draw fish to find the number in each bowl.

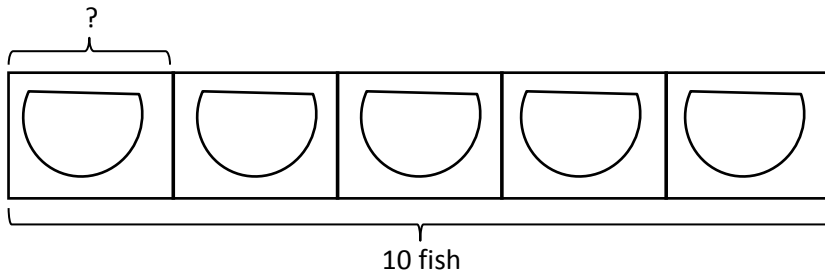

_____ $\times 5 = 10$

$10 \div 5 = \underline{\hspace{2cm}}$

There are _____ fish in each bowl.

3. Match.

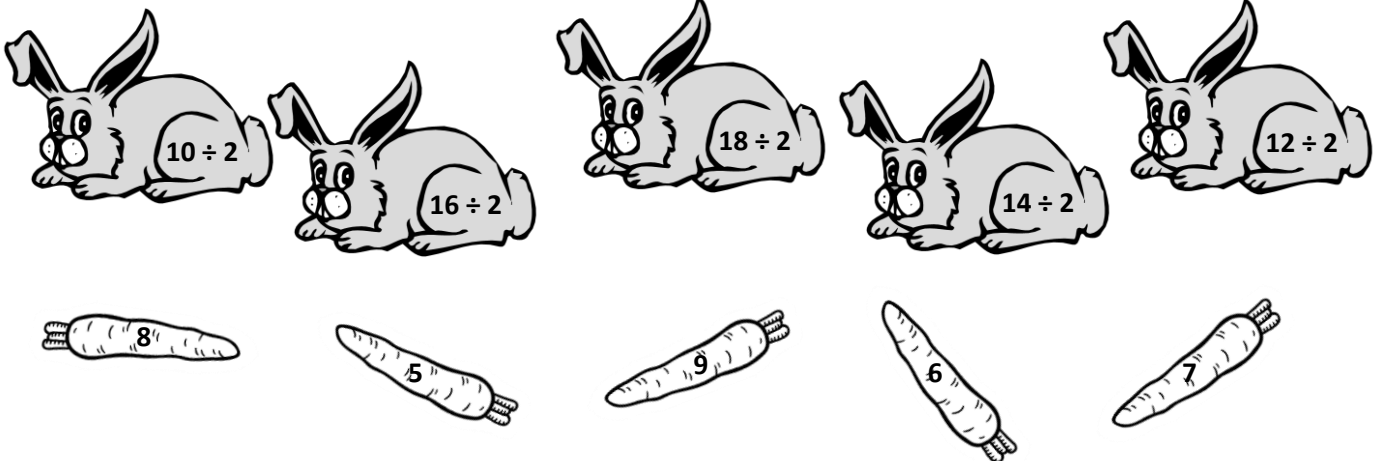

4. Laina buys 14 meters of ribbon. She cuts her ribbon into 2 equal pieces. How many meters long is each piece? Label the tape diagram to represent the problem, including the unknown.



Each piece is _____ meters long.

5. Roy eats 2 cereal bars every morning. Each box has a total of 12 bars. How many days will it take Roy to finish 1 box?

6. Sarah and Esther equally share the cost of a present. The present costs \$18. How much does Sarah pay?

Name _____

Date _____

1. Complete the related expressions.

$1 \times 3 = 3$
 $3 \div 3 = \underline{\quad}$

$2 \times 3 = 6$
 $6 \div 3 = \underline{\quad}$

$3 \times 3 = 9$
 $\underline{\quad} \div 3 = 3$

$4 \times 3 = \underline{\quad}$
 $\underline{\quad} \div 3 = 4$

$5 \times 3 = \underline{\quad}$
 $\underline{\quad} \div 3 = 5$

$6 \times 3 = \underline{\quad}$
 $\underline{\quad} \div 3 = 6$

$7 \times 3 = \underline{\quad}$
 $\underline{\quad} \div 3 = 7$

$8 \times 3 = \underline{\quad}$
 $\underline{\quad} \div 3 = 8$

$9 \times 3 = \underline{\quad}$
 $\underline{\quad} \div 3 = 9$

$10 \times 3 = \underline{\quad}$
 $\underline{\quad} \div 3 = 10$

2. Mr. Lawton picks tomatoes from his garden. He divides the tomatoes into bags of 3.

a. Circle to show how many bags he packs. Then skip-count to show the total number of tomatoes.

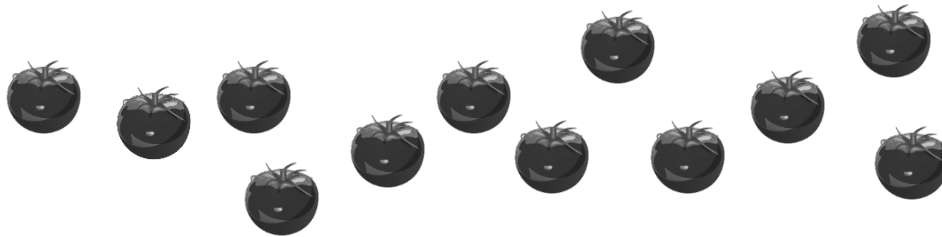

b. Draw and label a tape diagram to represent the problem.

_____ \div 3 = _____

Mr. Lawton packs _____ bags of tomatoes.

3. Camille buys a sheet of stamps that measures 15 centimeters long. Each stamp is 3 centimeters long. How many stamps does Camille buy? Draw and label a tape diagram to solve.

Camille buys _____ stamps.

4. Thirty third-graders go on a field trip. They are equally divided into 3 vans. How many students are in each van?

5. Some friends spend \$24 altogether on frozen yogurt. Each person pays \$3. How many people buy frozen yogurt?

Name _____

Date _____

1. Skip-count by fours. Match the answers to the appropriate multiplication problem.

4

8

4×4

4×8

4×6

4×5

4×10

4×1

4×9

4×7

4×2

4×3

2. Mr. Schmidt replaces each of the 4 wheels on 7 cars. How many wheels does he replace? Draw and label a tape diagram to solve.

Mr. Schmidt replaces _____ wheels altogether.

3. Trina makes 4 bracelets. Each bracelet has 6 beads. Draw and label a tape diagram to show the total number of beads Trina uses.

4. Find the total number of sides on 5 rectangles.

Name _____

Date _____

1. Label the tape diagrams and complete the equations. Then draw an array to represent the problems.

a.

$2 \times 4 = \underline{\hspace{2cm}}$

$4 \times 2 = \underline{\hspace{2cm}}$

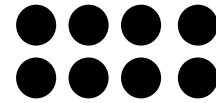

b.

$\underline{\hspace{2cm}} \times 4 = \underline{\hspace{2cm}}$

$4 \times \underline{\hspace{2cm}} = \underline{\hspace{2cm}}$

c.

$\underline{\hspace{2cm}} \times \underline{\hspace{2cm}} = 28$

$\underline{\hspace{2cm}} \times \underline{\hspace{2cm}} = 28$

2. Draw and label 2 tape diagrams to model how the statement in the box is true.

$$4 \times 6 = 6 \times 4$$

3. Grace picks 4 flowers from her garden. Each flower has 8 petals. Draw and label a tape diagram to show how many petals there are in total.

4. Michael counts 8 chairs in his dining room. Each chair has 4 legs. How many chair legs are there altogether?

Name _____

Date _____

1. Label the array. Then fill in the blanks below to make the statements true.

a. $6 \times 4 =$ _____

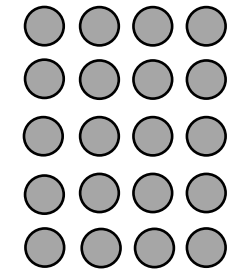

$(5 \times 4) =$ 20



$(1 \times 4) =$ _____

$(6 \times 4) = (5 \times 4) + (1 \times 4)$

$=$ 20 $+$ _____

$=$ _____

b. $7 \times 4 =$ _____

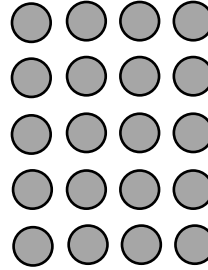

$(5 \times 4) =$ _____

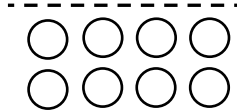

$(2 \times 4) =$ _____

$(7 \times 4) = (5 \times 4) + (2 \times 4)$

$=$ _____ $+$ _____

$=$ 28

c. $8 \times 4 =$ _____

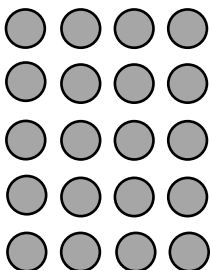

$(5 \times 4) =$ _____

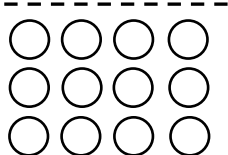

$(\text{ } \times 4) =$ _____

$(8 \times 4) = (5 \times 4) + (\text{ } \times 4)$

$=$ _____ $+$ _____

$=$ _____

d. $9 \times 4 =$ _____

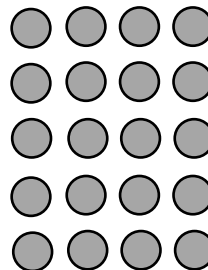

$(5 \times 4) =$ _____

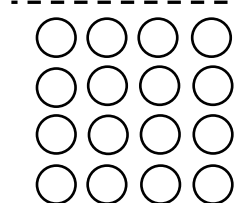

$(\text{ } \times 4) =$ _____

$(9 \times 4) = (5 \times 4) + (\text{ } \times 4)$

$=$ _____ $+$ _____

$=$ _____

2. Match the equal expressions.

$(5 \times 4) + (3 \times 4)$

$(5 \times 4) + (1 \times 4)$

$(5 \times 4) + (4 \times 4)$

$(5 \times 4) + (2 \times 4)$

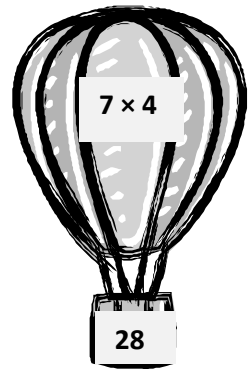
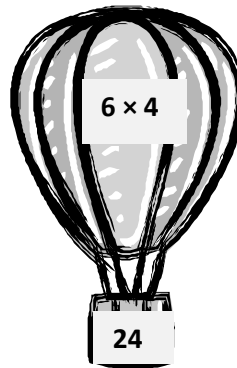
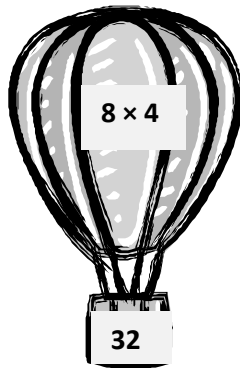
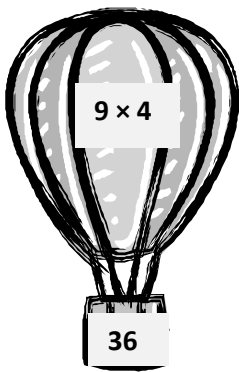

3. Nolan draws the array below to find the answer to the multiplication fact 4×10 . He says, " 4×10 is just double 4×5 !" Explain Nolan's strategy.

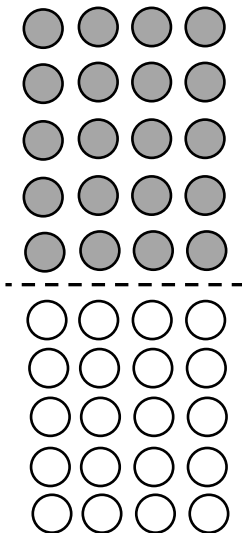

Name _____

Date _____

1. Use the array to complete the related number sentences.



$1 \times 4 = \underline{\quad 4 \quad}$

$\underline{\quad 4 \quad} \div 4 = 1$



$2 \times 4 = \underline{\hspace{2cm}}$

$\underline{\hspace{2cm}} \div 4 = 2$



$\underline{\hspace{2cm}} \times 4 = 12$

$12 \div 4 = \underline{\hspace{2cm}}$



$\underline{\hspace{2cm}} \times 4 = 16$

$16 \div 4 = \underline{\hspace{2cm}}$

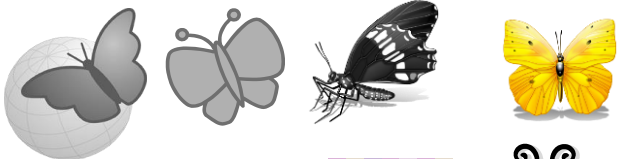

$\underline{\hspace{2cm}} \times \underline{\hspace{2cm}} = 20$

$20 \div \underline{\hspace{2cm}} = \underline{\hspace{2cm}}$



$\underline{\hspace{2cm}} \times \underline{\hspace{2cm}} = 24$

$24 \div \underline{\hspace{2cm}} = \underline{\hspace{2cm}}$



$\underline{\hspace{2cm}} \times 4 = \underline{\hspace{2cm}}$

$\underline{\hspace{2cm}} \div 4 = \underline{\hspace{2cm}}$



$\underline{\hspace{2cm}} \times 4 = \underline{\hspace{2cm}}$

$\underline{\hspace{2cm}} \div 4 = \underline{\hspace{2cm}}$



$\underline{\hspace{2cm}} \times \underline{\hspace{2cm}} = \underline{\hspace{2cm}}$

$\underline{\hspace{2cm}} \div \underline{\hspace{2cm}} = \underline{\hspace{2cm}}$



$\underline{\hspace{2cm}} \times \underline{\hspace{2cm}} = \underline{\hspace{2cm}}$

$\underline{\hspace{2cm}} \div \underline{\hspace{2cm}} = \underline{\hspace{2cm}}$

2. The baker packs 36 bran muffins in boxes of 4. Draw and label a tape diagram to find the number of boxes he packs.

3. The waitress arranges 32 glasses into 4 equal rows. How many glasses are in each row?

4. Janet paid \$28 for 4 notebooks. Each notebook costs the same amount. What is the cost of 2 notebooks?

Name _____

Date _____

1. $8 \times 10 =$ _____

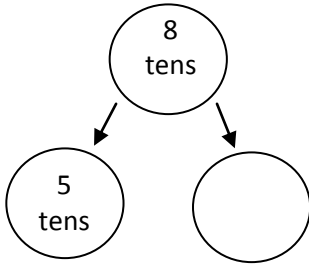

5 tens + _____ = 8 tens

$(5 \times 10) + (\text{_____} \times 10) =$

$50 + \text{_____} = \text{_____}$

$8 \times 10 = \text{_____}$

2. $7 \times 4 =$ _____

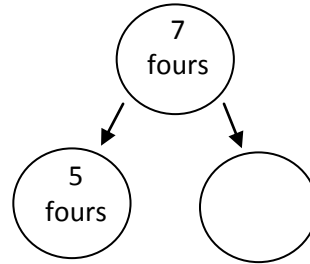

5 fours + _____ = 7 fours

$(5 \times 4) + (\text{_____} \times 4) =$

$20 + \text{_____} = \text{_____}$

$7 \times 4 = \text{_____}$

3. $9 \times 10 =$ _____

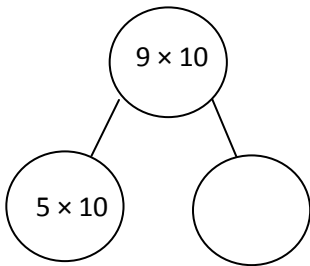

5 tens + _____ = 9 tens

$(5 \times 10) + (\text{_____} \times 10) =$

_____ + _____ = _____

$9 \times 10 = \text{_____}$

4. $10 \times 10 =$ _____

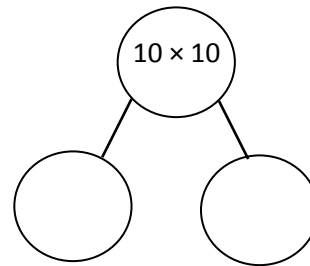

_____ + _____ = 10 tens

$(\text{_____} \times 10) + (\text{_____} \times 10) =$

_____ + _____ = _____

$10 \times 10 = \text{_____}$

5. There are 7 teams in the soccer tournament. 10 children play on each team. How many children are playing in the tournament?

There are _____ children playing in the tournament.

6. What is the total number of sides on 8 triangles?

7. There are 12 rows of bottled drinks in the vending machine. Each row has 10 bottles. How many bottles are in the vending machine?

Name _____

Date _____

1. Label the array. Then fill in the blanks below to make statements that are true.

a. $36 \div 3 = \underline{\hspace{2cm}}$

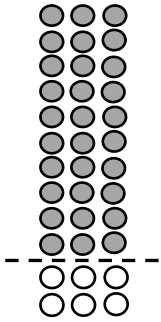

$(30 \div 3) = \underline{\hspace{2cm}}$

$(6 \div 3) = \underline{\hspace{2cm}}$

$(36 \div 3) = (30 \div 3) + (6 \div 3)$

$= \underline{10} + \underline{\hspace{1cm}}$

$= \underline{12}$

b. $25 \div 5 = \underline{\hspace{2cm}}$

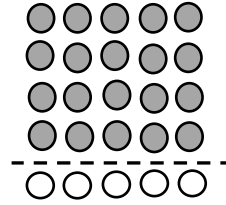

$(20 \div 5) = \underline{4}$

$(5 \div 5) = \underline{\hspace{2cm}}$

$(25 \div 5) = (20 \div 5) + (5 \div 5)$

$= \underline{4} + \underline{\hspace{1cm}}$

$= \underline{\hspace{2cm}}$

c. $28 \div 4 = \underline{\hspace{2cm}}$

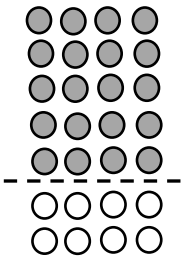

$(20 \div 4) = \underline{\hspace{2cm}}$

$(\underline{\hspace{1cm}} \div 4) = \underline{\hspace{2cm}}$

$(28 \div 4) = (20 \div 4) + (\underline{\hspace{1cm}} \div 4)$

$= \underline{\hspace{1cm}} + \underline{\hspace{1cm}}$

$= \underline{\hspace{2cm}}$

d. $32 \div 4 = \underline{\hspace{2cm}}$

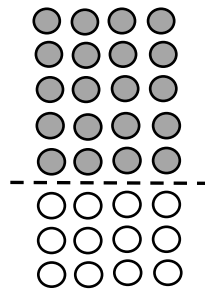

$(\underline{\hspace{1cm}} \div 4) = \underline{\hspace{2cm}}$

$(\underline{\hspace{1cm}} \div 4) = \underline{\hspace{2cm}}$

$(32 \div 4) = (\underline{\hspace{1cm}} \div 4) + (\underline{\hspace{1cm}} \div 4)$

$= \underline{\hspace{1cm}} + \underline{\hspace{1cm}}$

$= \underline{\hspace{2cm}}$

2. Match the equal expressions.

Four buckets are shown, each with a math expression on a label: $24 \div 2$, $36 \div 3$, $39 \div 3$, and $26 \div 2$. Below them are four beach balls, each with a math expression on a label: $(30 \div 3) + (6 \div 3)$, $(30 \div 3) + (9 \div 3)$, $(20 \div 2) + (6 \div 2)$, and $(20 \div 2) + (4 \div 2)$.

3. Nell draws the array below to find the answer to the division fact $24 \div 2$. Explain Nell’s strategy.

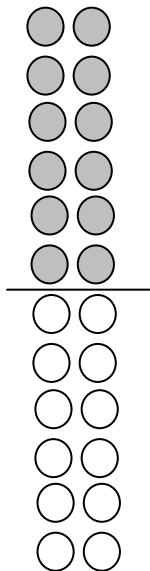

Name _____

Date _____

1. Ted buys 3 books and a magazine at the book store. Each book costs \$8. A magazine costs \$4.

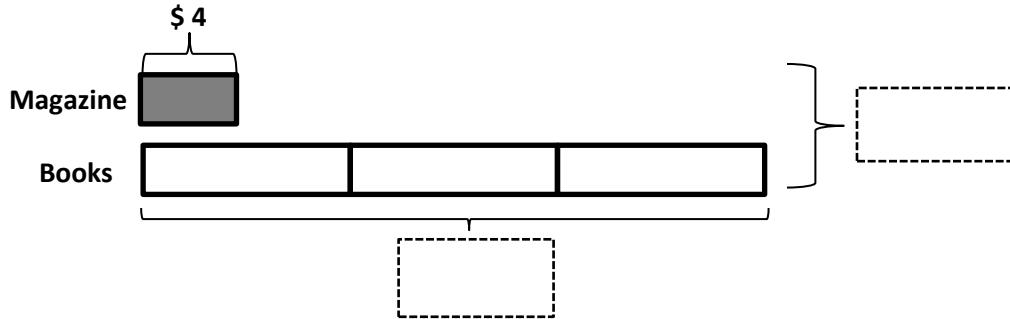

- a. What is the total cost of the books?
- b. How much does Ted spend altogether?

2. Seven children share 28 silly bands equally.

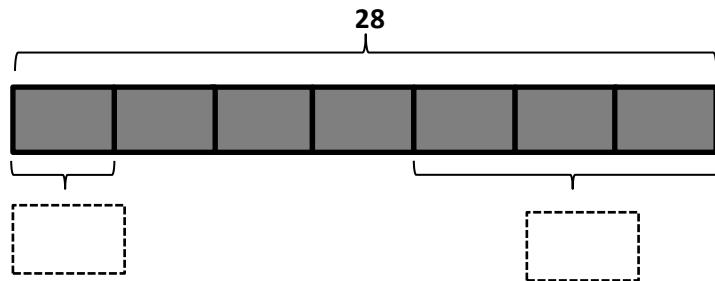

- a. How many silly bands does each child get?
- b. How many silly bands do 3 children get?

3. Eighteen cups are equally packed into 6 boxes. Two boxes of cups break. How many cups are unbroken?
-
4. There are 25 blue balloons and 15 red balloons at a party. Five children are given an equal number of each color balloon. How many blue and red balloons does each child get?
-
5. Twenty-seven pears are packed in bags of 3. Five bags of pears are sold. How many bags of pears are left?

Name _____

Date _____

1. Jason earns \$6 per week for doing all his chores. On the fifth week he forgets to take out the trash so he only earns \$4. Write and solve an equation to show how much Jason earns in 5 weeks.

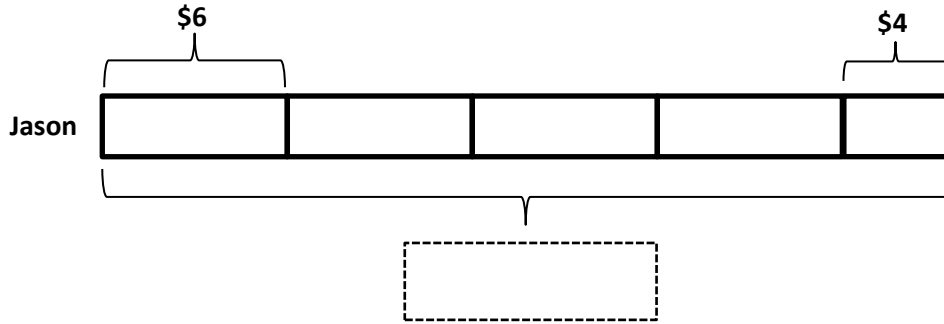

Jason earns _____.

2. Miss Lianto orders 4 packs of 7 markers. After passing out 1 marker to each student in her class, she has 6 left. Label the tape diagram to find how many students are in Miss Lianto's class.

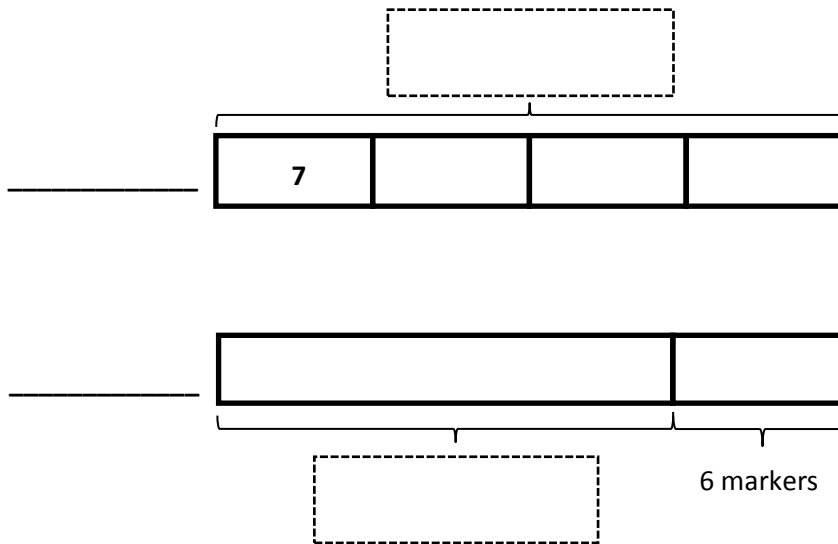

There are _____ students in Miss Lianto's class.

3. Orlando buys a box of 18 fruit snacks. Each box comes with an equal amount of strawberry, cherry, and grape flavored snacks. He eats all of the grape flavored snacks first. Draw and label a tape diagram to find how many fruit snacks he has left.

4. Eudora buys 21 m of ribbon. She cuts the ribbon so that each piece measures 3 m in length.
- a. How many pieces of ribbon does she cut?
- b. If Eudora needs a total of 12 pieces of ribbon, how many more pieces of ribbon does she need?

Name _____

Date _____

1. The picture below shows 4 groups of 2 slices of watermelon. Write repeated addition and multiplication sentences to represent the picture.

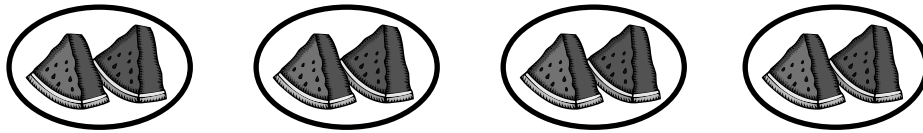

$$2 + \underline{\quad} + \underline{\quad} + \underline{\quad} = \underline{\quad}$$

$$4 \times \underline{\quad} = \underline{\quad}$$

2. Draw a picture to show $3 + 3 + 3 = 9$. Then write a multiplication sentence to represent the picture.

Name _____

Date _____



a. There are 4 rows of stars. How many stars are in each row? _____

b. Write a multiplication fact to describe the total number of stars. _____

2. Judy collects seashells. She arranges them in 3 rows of 6. Draw Judy's array to show how many seashells she has all together. Then write a multiplication sentence to describe the array.

Name _____

Date _____

Draw an array that shows 5 rows of 3 squares. Then show a number bond where each part represents the amount in one row.

Name _____

Date _____

1. There are 16 glue sticks for the class. The teacher divides them into 4 equal groups. Draw the number of glue sticks in each group.

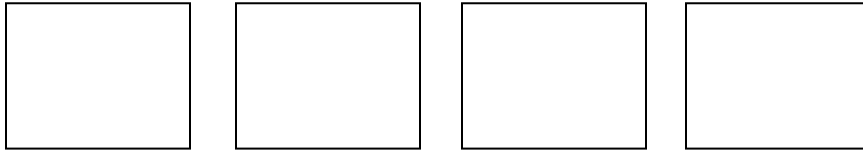

There are _____ glue sticks in each group.

$$16 \div \underline{\quad} = \underline{\quad}$$

2. Draw a picture to show $15 \div 3$. Then complete the division sentence.

$$15 \div 3 = \underline{\quad}$$

Name _____

Date _____

1. Divide 12 triangles into groups of 6.

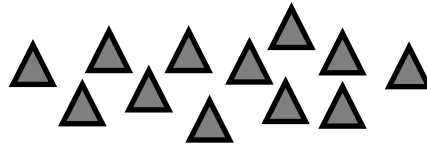

$$12 \div 6 = \underline{\quad\quad}$$

2. Spencer buys 20 strawberries to make smoothies. Each smoothie needs 5 strawberries. Use a count-by to find the number of smoothies Spencer can make. Make a drawing to match your counting.

Name _____

Date _____

1. Cesar arranges 12 notecards into rows of 6 for his presentation. Draw an array to represent the problem.

$$12 \div 6 = \underline{\hspace{2cm}}$$

$$\underline{\hspace{2cm}} \times 6 = 12$$

What do the unknown factor and quotient represent? _____

Name _____

Date _____

$$2 \times 5 = 5 \times 2$$

Do you agree or disagree with the statement in the box? Draw arrays and use skip-counting to explain your thinking.

Name _____

Date _____

1. Mary Beth organizes stickers on a page in her sticker book. She arranges them in 3 rows and 4 columns. Draw an array to show Mary Beth's stickers.
 - a. Use your array to write a multiplication sentence to find Mary Beth's total number of stickers.
 - b. Label your array to show how you skip-count to solve your multiplication sentence.
 - c. Use what you know about the commutative property to write a different multiplication sentence for your array.

Name _____

Date _____

1. Mrs. Stern roasts cloves of garlic. She places 10 rows of two cloves on a baking sheet.

Write a multiplication sentence to describe the number of cloves Mrs. Stern bakes.

_____ × _____ = _____

2. When the garlic is roasted, Mrs. Stern uses some for a recipe, leaving 2 rows of two garlic cloves on the pan.

a. Complete the number sentence below to show how many garlic cloves she uses.

_____ twos – _____ twos = _____ twos

b. 20 – _____ = 16

c. Write a multiplication sentence to describe the number of garlic cloves she uses.

_____ × 2 = _____

Name _____

Date _____

1. $6 \times 3 =$ _____

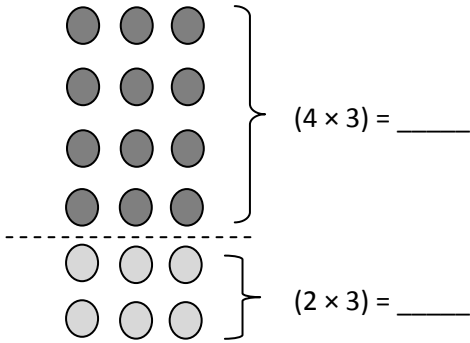

$(4 \times 3) + (2 \times 3) =$ _____ + _____

$6 \times 3 =$ _____ + _____

_____ $\times 3 =$ _____

2. $7 \times 3 =$ _____

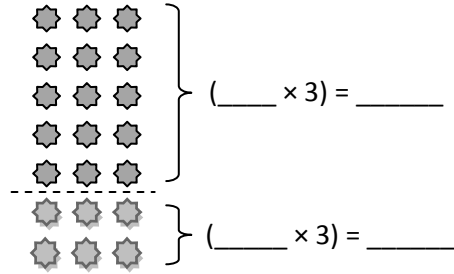

$(5 \times 3) + (2 \times 3) =$ _____ + _____

$7 \times 3 =$ _____ + _____

_____ $\times 3 =$ _____

Ms. McCarty has 18 stickers. She puts 2 stickers on each homework paper. How many homework papers does she have? Model the problem with both an array and a labeled tape diagram.

Name _____

Date _____

There are 14 mints in 1 box. Cecilia eats 2 mints each day. How many days does it take Cecilia to eat 1 box of mints? Draw and label a tape diagram to solve.

It takes Cecilia _____ days to eat 1 box of mints.

Name _____

Date _____

1. Andrea has 21 apple slices. She uses 3 apple slices to decorate 1 pie. How many pies does Andrea make? Draw and label a tape diagram to solve.

2. There are 24 soccer players on the field. They form 3 equal teams. How many players are on each team?

Name _____

Date _____

Arthur has 4 boxes of chocolates. Each box has 6 chocolates inside. How many chocolates does Arthur have altogether? Draw and label a tape diagram to solve.

Name _____

Date _____

Draw and label 2 tape diagrams to show that $4 \times 3 = 3 \times 4$. Use your diagrams to explain how you know.

Name _____

Date _____

Destiny says, “I can use 5×4 to find the answer to 7×4 .” Use the array below to explain Destiny’s strategy using words and numbers.

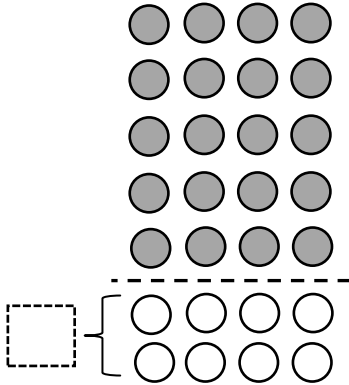

$(7 \times 4) = (5 \times 4) + (2 \times 4)$ $= \underline{\quad} + \underline{\quad}$ $= \underline{\quad}$
--

Name _____

Date _____

Dylan used the distributive property to solve a multiplication problem. Look at his work below, write the multiplication problem Dylan solved and complete the number bond.

Dylan's work:

$$(5 \times 4) + (1 \times 4) =$$

$$20 + 4 = 24$$

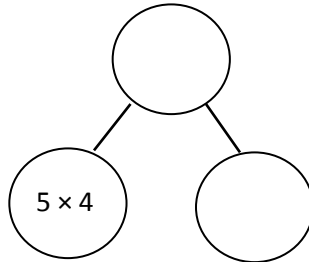

$$\underline{\quad} \times \underline{\quad} = \underline{\quad}$$

Name _____

Date _____

Complete the equations below to solve $22 \div 2 = \underline{\hspace{2cm}}$.

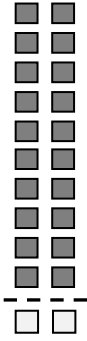

$(20 \div 2) = \underline{\hspace{2cm}}$

$(\underline{\hspace{2cm}} \div 2) = \underline{\hspace{2cm}}$

$(22 \div 2) = (20 \div 2) + (\underline{\hspace{2cm}} \div 2)$

$= \underline{\hspace{2cm}} + \underline{\hspace{2cm}}$

$= \underline{\hspace{2cm}}$

Name _____

Date _____

1. Thirty-two jellybeans are shared by 8 students.

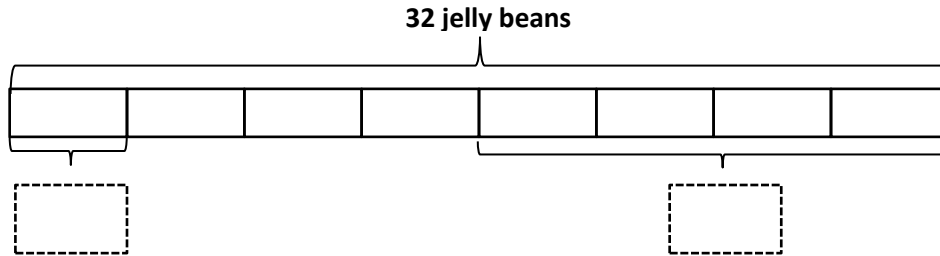

- a. How many jellybeans will each student get?

- b. How many jellybeans will 4 students get?

2. The teacher has 30 apple slices and 20 pear slices. Five children equally share all of the fruit slices. How many fruit slices does each child get?

Name _____

Date _____

Ms. Egeregor buys 27 books for her classroom library. She buys an equal amount of fiction, nonfiction, and poetry books. She shelves all of the poetry books first. Draw and label a tape diagram to show how many books Ms. Egeregor has left to shelve.

Name _____

Date _____

1. Fill in the blanks to make true statements.



a. 4 groups of five = _____

4 fives = _____

$4 \times 5 =$ _____

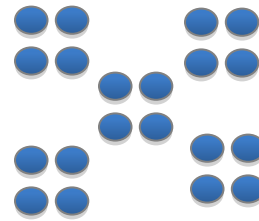

b. 5 groups of four = _____

5 fours = _____

$5 \times 4 =$ _____



c. $6 + 6 + 6 =$ _____

_____ groups of six = _____

$3 \times$ _____ = _____



d. $3 +$ _____ $+$ _____ $+$ _____ $+$ _____ $+$ _____ $+$ _____ $=$ _____

6 groups of _____ = _____

$6 \times$ _____ = _____

2. The picture below shows 3 groups of hot dogs. Does the picture below show 3×3 ? Explain why or why not.



3. Draw a picture to show $4 \times 2 = 8$.

4. Circle the markers below to show 3 groups of 6. Write addition and multiplication sentences to represent the problem.



Name _____

Date _____

Use the arrays below to answer each set of questions.

1.



a. How many rows of erasers are there? _____

b. How many erasers are there in each row? _____

2.

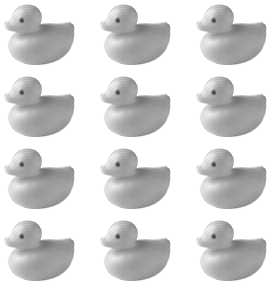

a. What is the number of rows? _____

b. What is the number of objects in each row? _____

3.

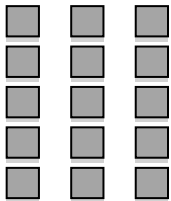

a. There are 3 squares in each row. How many squares are in 5 rows? _____

b. Write a multiplication fact to describe the array. _____

4.



a. There are 6 rows of stars. How many stars are in each row? _____

b. Write a multiplication fact to describe the array. _____

5. The triangles below show 3 groups of 4.

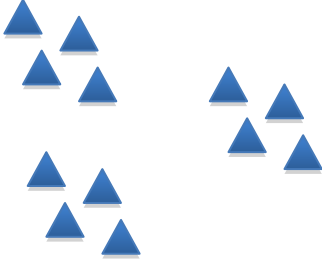

a. Redraw the triangles as an array that shows 3 rows of 4.

b. Compare the drawing to your array. How are they the same? How are they different?

6. Roger has a collection of stamps. He arranges the stamps into 5 rows of 4. Draw an array to represent Roger’s stamps. Then write a multiplication sentence to describe the array.

7. Kimberly arranges her 18 markers in an array. Draw an array that Kimberly might make. Then write a multiplication sentence to match your array.

Name _____

Date _____

Solve problems 1–4 using the pictures for each problem.



1. There are 5 pineapples in each group. How many pineapples are there in 5 groups?

- a. Number of groups: _____ Size of each group: _____
- b. $5 \times 5 =$ _____
- c. There are _____ pineapples altogether.

2. There are _____ oranges in each basket. How many oranges are there in 6 baskets?

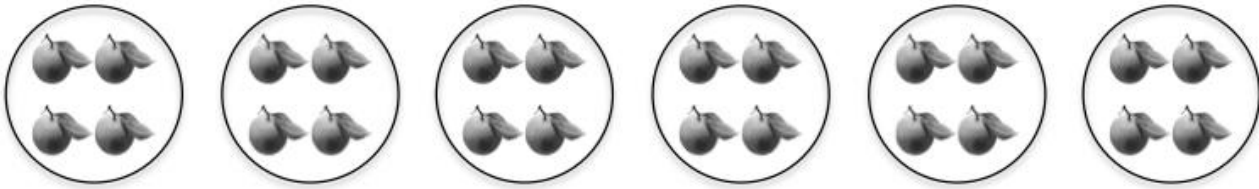

- a. Number of groups: _____ Size of each group: _____
- b. $6 \times$ _____ $=$ _____
- c. There are _____ oranges altogether.

3. There are 4 bananas in each row. How many bananas in _____ rows?

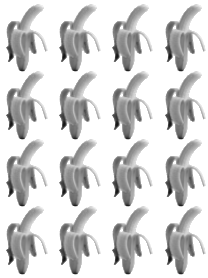

a. Number of rows: _____ Size of each row: _____

b. _____ \times 4 = _____

c. There are _____ bananas altogether.

4. There are _____ peppers in each row. How many peppers are there in 6 rows?



a. Number of rows: _____ Size of each row: _____

b. _____ \times _____ = _____

c. There are _____ peppers altogether.

5. Draw an array using factors 4 and 2. Then show a number bond where each part represents the amount in one row.

Name _____

Date _____

1.

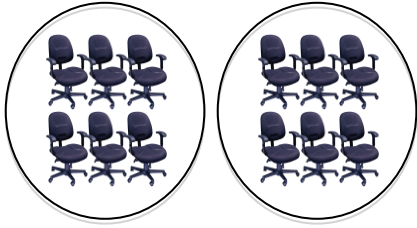

Divide 12 chairs into 2 equal groups.
There are _____ chairs in each group.

2.

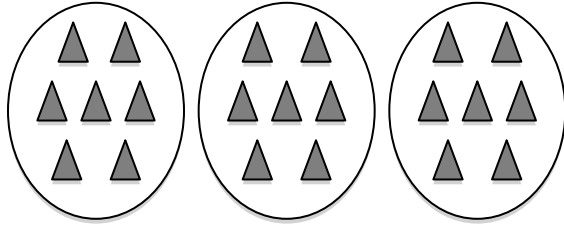

Divide 21 triangles into 3 equal groups.
There are _____ triangles in each group.

3.

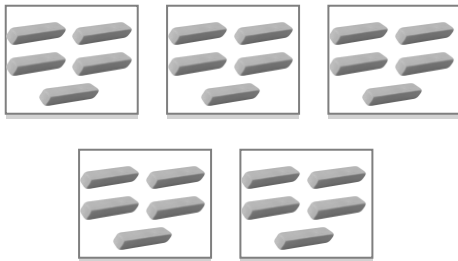

Divide 25 erasers into _____ equal groups.
There are _____ erasers in each group.

4.

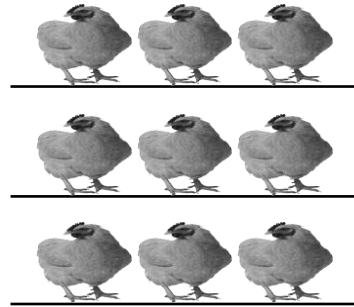

Divide _____ chickens into _____ equal groups.
There are _____ chickens in each group.
 $9 \div 3 = \underline{\hspace{2cm}}$

5.



There are _____ buckets in each group.
 $12 \div 4 = \underline{\hspace{2cm}}$

6.

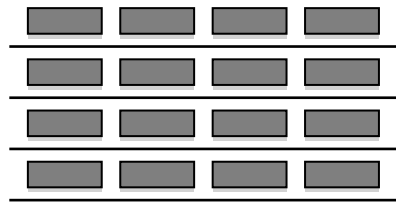

$16 \div 4 = \underline{\hspace{2cm}}$

7. Andrew has 21 keys. He puts them in 3 equal groups. How many keys are in each group?



There are _____ keys in each group.

$21 \div 3 = \underline{\hspace{2cm}}$

8. Mr. Doyle has 20 pencils. He divides them equally between 4 tables. Draw the pencils on each table.

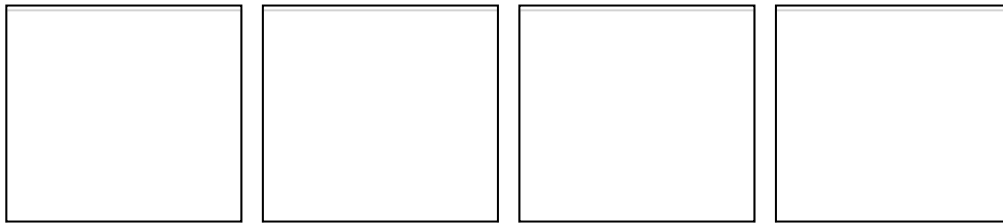

There are _____ pencils on each table.

$20 \div \underline{\hspace{1cm}} = \underline{\hspace{2cm}}$

9. Jenna has markers. The picture shows how she placed them on her desk. Write a division sentence to represent how she equally grouped her markers.

There are _____ markers in each row.

$\underline{\hspace{2cm}} \div \underline{\hspace{1cm}} = \underline{\hspace{2cm}}$

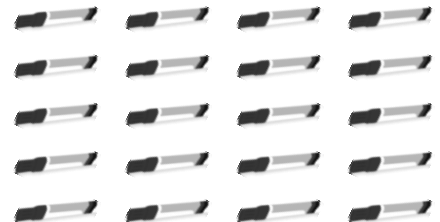

Name _____

Date _____

1.

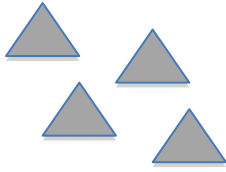

Divide 4 triangles into groups of 2.

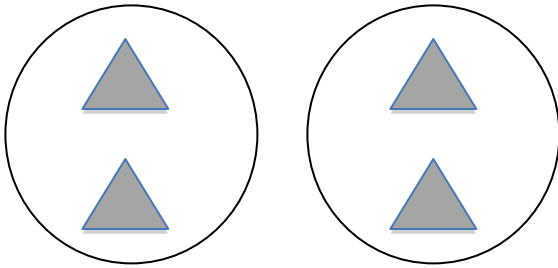

There are _____ groups of 2 triangles.

$4 \div 2 = 2$

2.

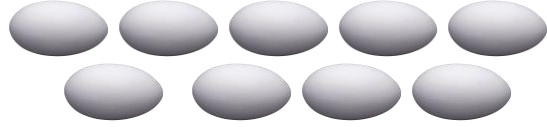

Divide 9 eggs into groups of 3.

There are _____ groups.

$9 \div 3 = \underline{\hspace{2cm}}$

3.



Divide 12 buckets of paint into groups of 3.

$12 \div 3 = \underline{\hspace{2cm}}$

4.

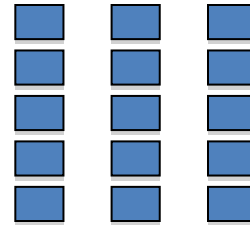

Group the squares to show $15 \div 5 = \underline{\hspace{2cm}}$ where the unknown represents the number of groups.

How many groups are there? _____

5. Daniel has 12 apples. He puts 6 apples in each bag. Circle the apples to find the number of bags Daniel makes.



- a. Write a division sentence where the answer represents the number of Daniel's bags.
- b. Draw a number bond to show Daniel's apples.
6. Jacob is drawing cats. He draws 4 legs on each cat, and a total of 24 legs.
- a. Use a count-by to find the number of cats Jacob draws. Make a drawing to match your counting.
- b. Write a division sentence to represent the problem.

Name _____

Date _____

1. Mr. Hannigan puts 12 pencils into boxes. Each box holds 4 pencils. Circle groups of 4 to show the pencils in each box.



Mr. Hannigan needs _____ boxes.

_____ \times 4 = 12

12 \div 4 = _____

2. Mr. Hannigan places 12 pencils into 3 equal groups. Draw to show how many pencils are in each group.

There are _____ pencils in each group.

3 \times _____ = 12

12 \div 3 = _____

3. Use an array to model Problem 1.

a) _____ \times 4 = 12

12 \div 4 = _____

The number in the blanks represents:

_____.

b) 3 \times _____ = 12

12 \div 3 = _____

The number in the blanks represents:

_____.

Name _____

Date _____

1. a. Count by 2 seven times.

_____, _____, _____, _____, _____, _____, _____

b. Draw an array that matches your count-by.

c. Write a multiplication sentence that represents the total number of objects in your array.

_____ × _____ = _____

2. a. Count by 7 two times.

_____, _____

b. Draw an array that matches your count-by.

c. Write a multiplication sentence that represents the total number of objects in your array.

_____ × _____ = _____

3. a. Compare your work in Problems 1 and 2. Turn your paper as you study the arrays to look at them in different ways.

b. Why are the factors in your multiplication sentences in a different order?

4. Count by the unit (the number in word form) the number of times indicated. Write the multiplication sentence that matches your count-by. The first one is done for you.

a. 2 twos: $2 \times 2 = 4$

d. 2 fours: _____

g. 2 fives: _____

b. 3 twos: _____

e. 4 twos: _____

g. 6 twos: _____

c. 2 threes: _____

f. 5 twos: _____

h. 2 sixes: _____

5. Write and solve a different multiplication sentence to describe each array.

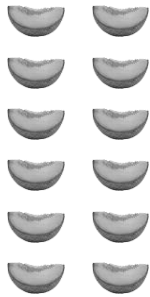

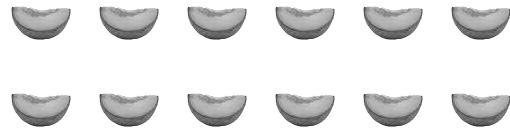

6. Angel writes $2 \times 8 = 8 \times 2$ in his notebook. Do you agree or disagree? Draw arrays to help explain your thinking.

7. Find the missing factor to make each number sentence true.

$2 \times 6 = 6 \times \underline{\quad}$

$\underline{\quad} \times 2 = 2 \times 7$

$9 \times 2 = \underline{\quad} \times 9$

$2 \times \underline{\quad} = 10 \times 2$

8. Tamia buys 2 bags of candy. Each bag has 7 pieces of candy in it.

a. Draw an array to show how many pieces of candy Tamia has altogether.

b. Write and solve a multiplication sentence to describe the array.

c. Use the commutative property to write and solve a different multiplication sentence for the array.

Name _____

Date _____

1. a. Count by 3 six times.

_____, _____, _____, _____, _____, _____

b. Draw an array that matches your count-by.

2. a. Count by 6 three times.

_____, _____, _____

b. Draw an array that matches your count-by.

2. Write multiplication expressions below to represent your arrays in Problems 1 and 2. Use the commutative property to make the equation true.

$$\begin{array}{ccc} \underline{\hspace{2cm}} \times \underline{\hspace{2cm}} & = & \underline{\hspace{2cm}} \times \underline{\hspace{2cm}} \\ \text{Problem 1} & & \text{Problem 2} \end{array}$$

3. Count by the unit (the number in word form) the number of times indicated. Write the multiplication sentence that matches your count by. The first one is done for you.

a. 5 threes: $5 \times 3 = 15$

d. 3 sixes: _____

g. 8 threes: _____

b. 3 fives: _____

e. 7 threes: _____

h. 3 nines: _____

c. 6 threes: _____

f. 3 sevens: _____

i. 10 threes: _____

4. Find the unknowns that make the number sentences true. Then draw a line between related facts.

a. $3 + 3 + 3 + 3 + 3 + 3 =$ _____

d. $3 \times 9 =$ _____

b. $3 \times 5 =$ _____

e. _____ $= 6 \times 3$

c. 8 threes + 1 three = _____

f. $15 = 5 \times$ _____

5. Fernando puts 3 pictures on each page of his photo album. He puts pictures on 8 pages.
- Use circles to draw an array that represents the total number of pictures in Fernando's photo album.
 - Use your array to write and solve a multiplication sentence to find Fernando's total number of pictures.
 - Fernando adds 2 more pages to his book. He puts 3 pictures on each new page. Draw x's to show the new pictures on the array in Part A.
 - Write and solve a multiplication sentence to find the new total number of pictures in Fernando's album.
6. Ivania recycles. She gets 3 cents for every can she recycles.
- How much money does Ivania make if she recycles 4 cans?

$$\underline{\hspace{2cm}} \times \underline{\hspace{2cm}} = \underline{\hspace{2cm}} \text{ cents}$$

- How much money does she make if she recycles 7 cans?

$$\underline{\hspace{2cm}} \times \underline{\hspace{2cm}} = \underline{\hspace{2cm}} \text{ cents}$$

Name _____

Date _____

1. Dan organizes his star stickers into 3 rows of 4. Irene adds 2 more rows of stickers. Complete the number sentences to describe the total number of stickers in the array.



a. $(4 + 4 + 4) + (4 + 4) =$ _____

b. 3 fours + _____ fours = _____ fours

c. _____ $\times 5 =$ _____

2. $7 \times 2 =$ _____

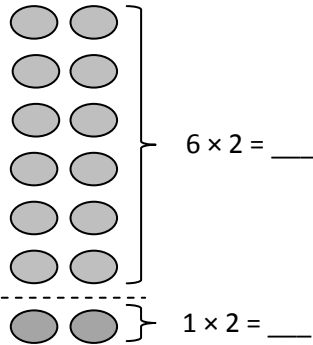

$12 + 2 =$ _____

_____ $\times 2 = 14$

3. $9 \times 3 =$ _____

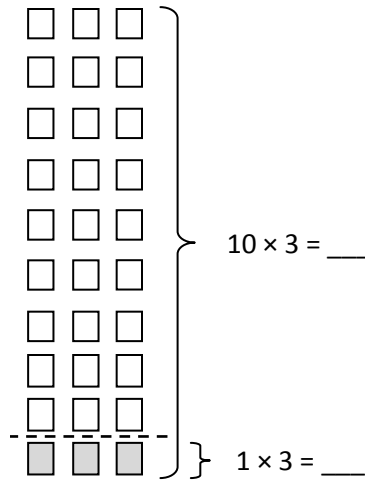

$30 -$ _____ $= 27$

_____ $\times 3 = 27$

4. Franklin collects stickers. He organizes his stickers in 5 rows of 4 on his table.

Draw an array that represents Franklin's stickers using an x to show each sticker.

$$5 \times 4 = \underline{\hspace{2cm}}$$

5. Franklin adds 2 more rows. Use circles to show his new stickers on the array in part 3a.

- a. Write and solve a multiplication sentence to represent the circles you added to the array.

$$\underline{\hspace{2cm}} \times 4 = \underline{\hspace{2cm}}$$

- b. Complete the addition sentence to show how you added the totals of 2 multiplication facts to find Franklin's total number of stickers.

$$\underline{\hspace{2cm}} + \underline{\hspace{2cm}} = 28$$

- c. Complete the unknown to show Franklin's total number of stickers.

$$\underline{\hspace{2cm}} \times 4 = 28$$

Name _____

Date _____

1. $6 \times 3 =$ _____

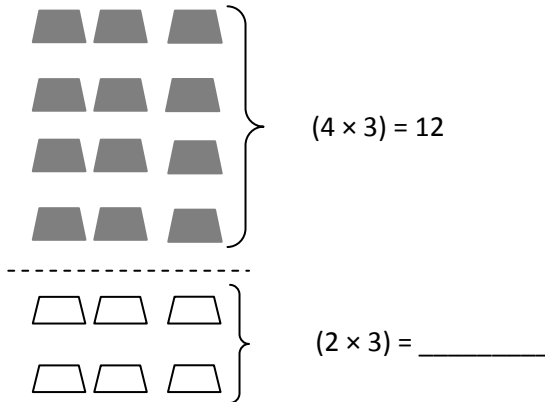

$12 +$ _____ $=$ _____

$6 \times 3 =$ _____

2. $8 \times 2 =$ _____

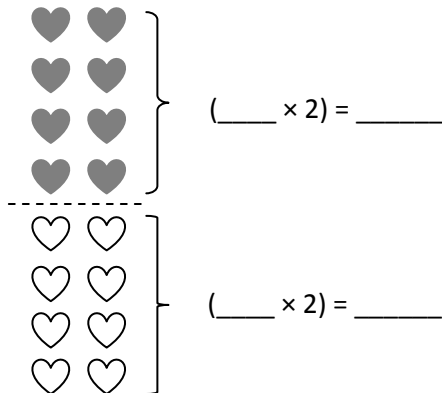

$(4 \times 2) + (4 \times 2) =$ _____ $+$ _____

_____ $\times 2 =$ _____

3. Adriana is organizing her books on shelves. She puts 3 books in each row.
- a. Use the multiplication sentences on the right to draw arrays to show the books on Adriana’s top and bottom shelves.

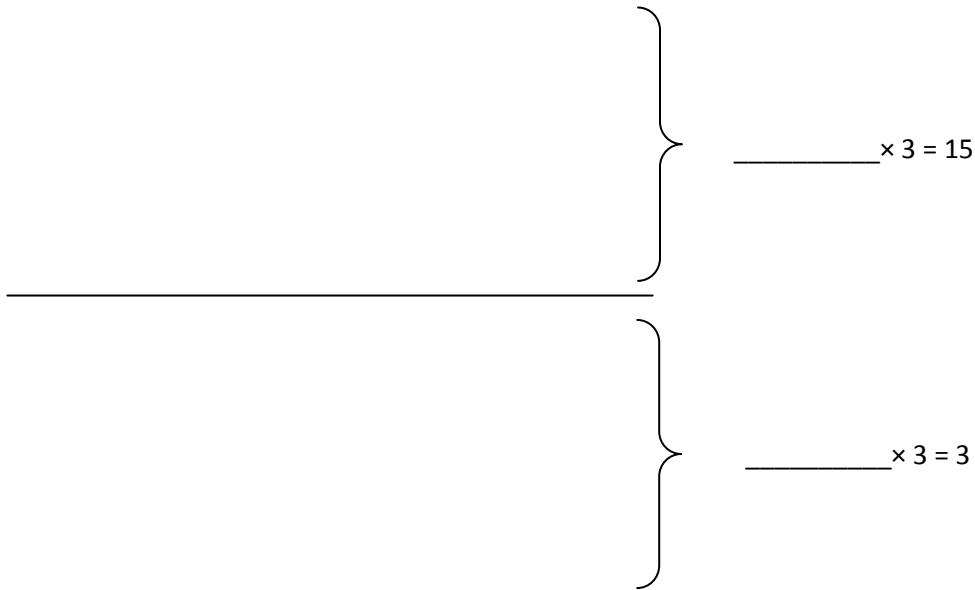

- b. Adriana calculates the total number of books as shown below. Use the array you drew to help explain her calculation.

$6 \times 3 = 15 + 3 = 18$

Name _____

Date _____

1. Fred has 10 pears. He puts 2 pears in each basket.
 - a. Draw an array where each column represents a basket of pears.

_____ ÷ 2 = _____

- b. Redraw the pears in each basket as a unit in the tape diagram. Label the diagram with known and unknown information from the problem.

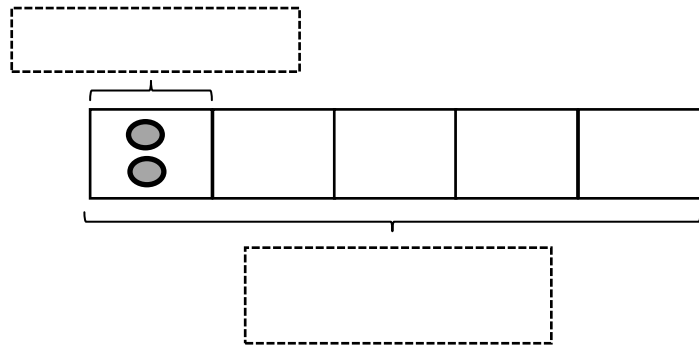

2. Ms. Meyer organizes 15 clipboards equally into 3 boxes. How many clipboards are in each box? Model the problem with both an array and a labeled tape diagram. Show each column as the number of clipboards in each box.

There are _____ clipboards in each box.

3. Sixteen action figures are arranged equally on 2 shelves. How many action figures are on each shelf? Model the problem with both an array and a labeled tape diagram. Show each column as the number of action figures on each shelf.
4. Jasmine puts 18 hats away. She puts an equal number of hats on 3 shelves. How many hats are on each shelf? Model the problem with both an array and a labeled tape diagram. Show each column as the number of hats on each shelf.
5. Corey checks out 2 books a week from the library. How many weeks will it take him to check out a total of 14 books?

Name _____

Date _____

1. 10 people wait in line for the roller coaster. 2 people sit in each car. Find the total number of cars needed.

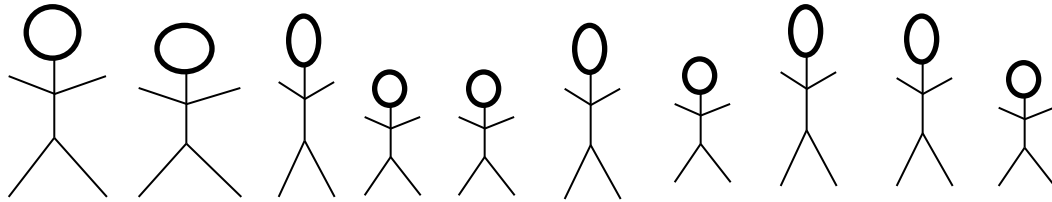

$10 \div 2 = \underline{\hspace{2cm}}$

There are _____ cars needed.

2. Mr. Ramirez divides 12 frogs equally into 6 groups for students to study. How many frogs are in each group? Label known and unknown information on the tape diagram to help you solve.

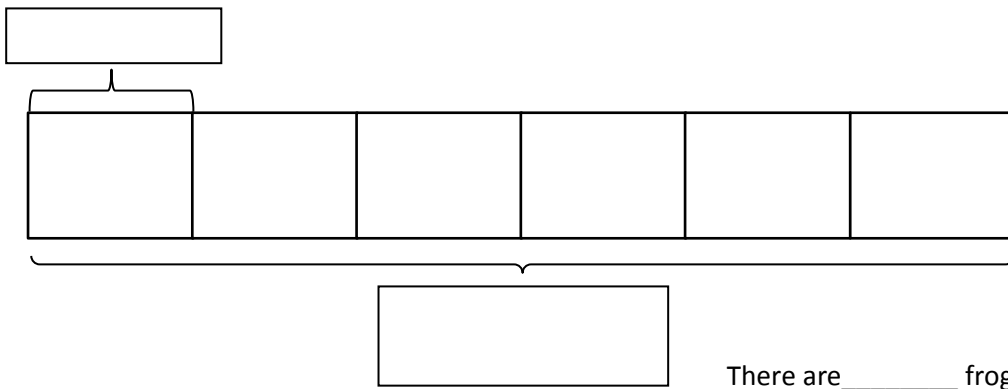

There are _____ frogs in each group.

3. Match.

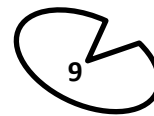
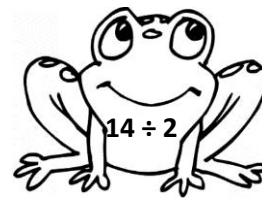
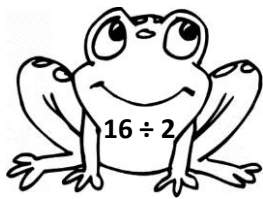
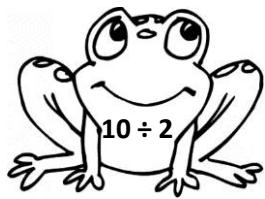

4. Betsy pours 16 cups of water to equally fill 2 bottles. How many cups of water are in each bottle? Label the tape diagram to represent the problem, including the unknown.

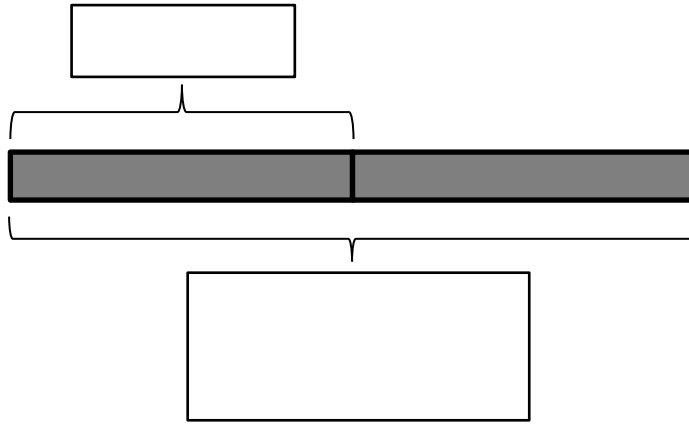

There are _____ cups of water in each bottle.

5. An earthworm tunnels 2 cm into the ground each day. The earthworm tunnels at about the same pace every day. How many days will it take the earthworm to tunnel 14 cm?

6. Sebastian and Teshawn go to the movies. The tickets cost \$16 in total. The boys share the cost equally. How much does Teshawn pay?

Name _____

Date _____

1. Complete the related expressions.

$2 \times 3 = 6$ $6 \div 3 = \underline{\quad}$
--

$1 \times 3 = \underline{\quad}$ $3 \div 3 = \underline{\quad}$
--

$7 \times 3 = \underline{\quad}$ $\underline{\quad} \div 3 = 7$
--

$9 \times 3 = \underline{\quad}$ $\underline{\quad} \div 3 = 9$
--

2. Ms. Jones' pet fish are shown below. She keeps 3 fish in each tank.

a. Circle to show how many fish tanks she has. Then skip-count to find the total number of fish.

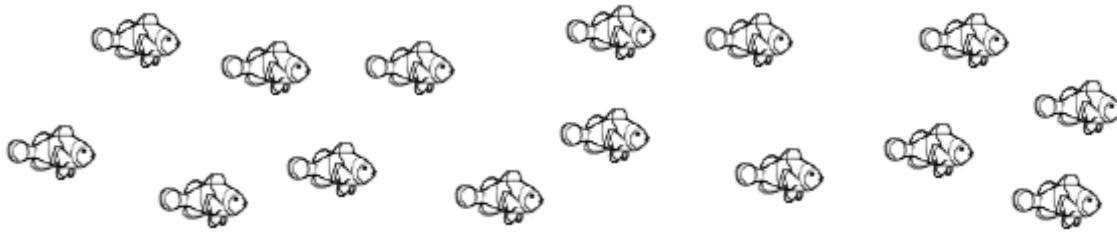

b. Draw and label a tape diagram to represent the problem.

_____ \div 3 = _____

Ms. Jones has _____ fish tanks.

3. Juan buys 18 meters of wire. He cuts the wire into pieces that are each 3 meters long. How many pieces of wire does he cut?

4. A teacher has 24 pencils. They are divided equally among 3 students. How many pencils does each student get?

5. There are 27 third graders working in groups of 3. How many groups of third graders are there?

Name _____

Date _____

1. Skip-count by fours. Match the answers to the appropriate multiplication problem.

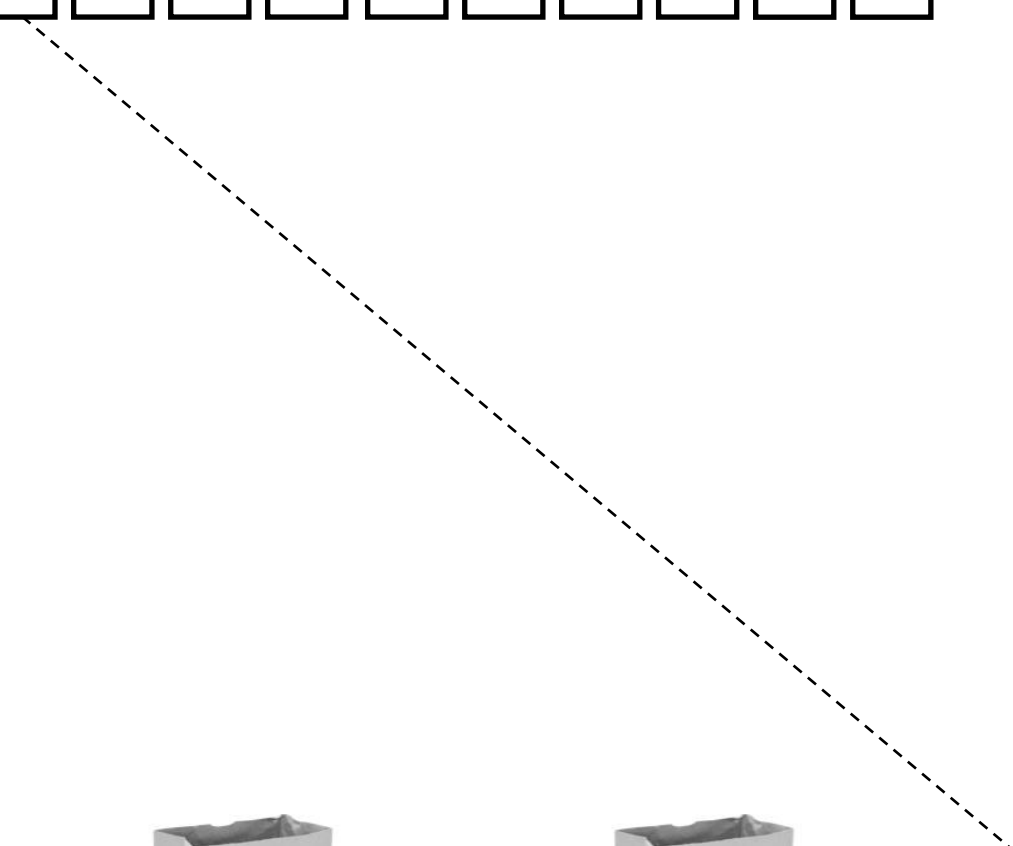

2. Lisa places 5 rows of 4 juice boxes in the refrigerator. Draw an array and skip-count to find the total number of juice boxes.

$$\underline{\hspace{2cm}} \times 4 = \underline{\hspace{2cm}}$$

There are juice boxes in total.

-
2. 6 folders are placed on each table. How many folders are there on 4 tables? Draw and label a tape diagram to solve.

-
3. Find the total number of corners on 8 squares.

Name _____

Date _____

1. Label the tape diagrams and complete the equations. Then draw an array to represent the problems.

a.

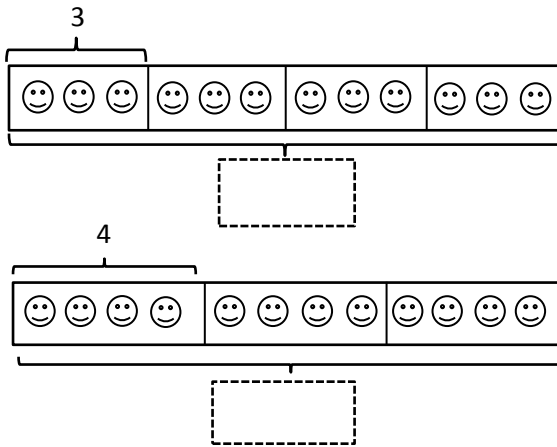

$4 \times 3 = \underline{\quad}$

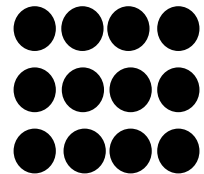

$3 \times 4 = \underline{\quad}$

b.

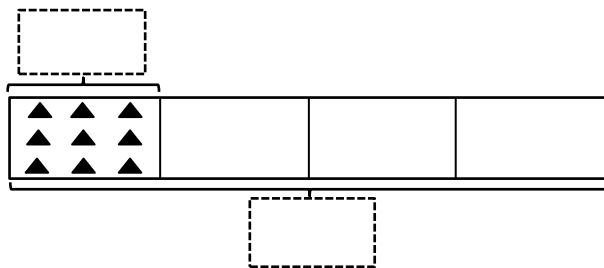

$4 \times \underline{\quad} = \underline{\quad}$

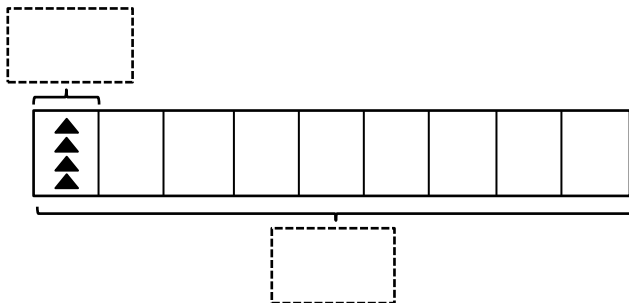

$\underline{\quad} \times 4 = \underline{\quad}$

C.

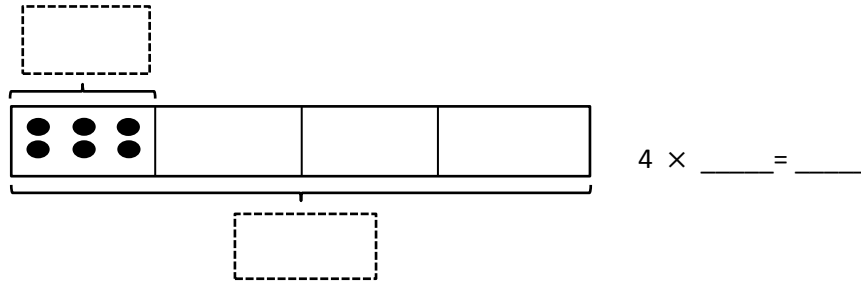
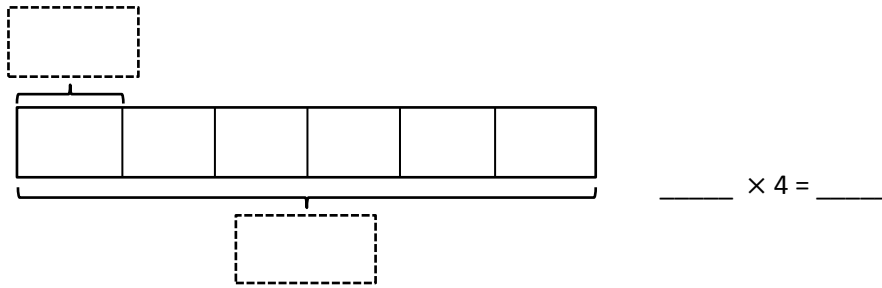

2. 7 clowns hold 4 balloons each at the fair. Draw and label a tape diagram to show the total number of balloons the clowns hold.

3. George swims 7 laps in the pool each day. How many laps does George swim after 4 days? Draw and label a tape diagram to solve.

Name _____

Date _____

1. Label the array. Then fill in the blanks below to make the statements true.

a. $6 \times 4 =$ _____

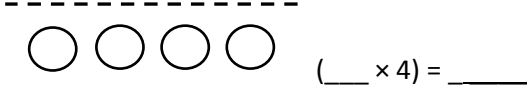
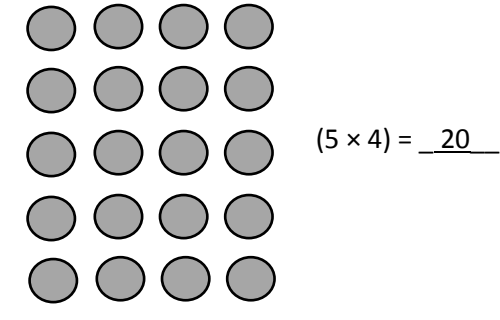

$(6 \times 4) = (5 \times 4) + (\quad \times 4)$

$= \underline{20} + \underline{\quad}$

$= \underline{\quad}$

b. $8 \times 4 =$ _____

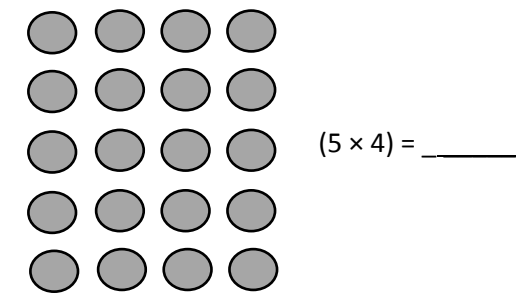

$(8 \times 4) = (5 \times 4) + (\quad \times 4)$

$= \underline{\quad} + \underline{\quad}$

$= \underline{\quad}$

2. Match the multiplication facts with their answers.

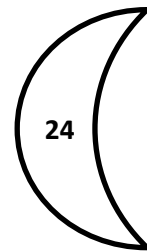
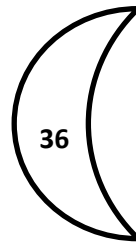
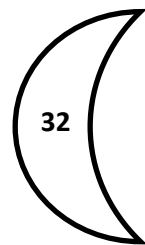
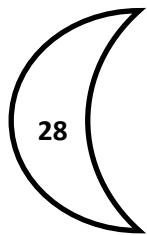
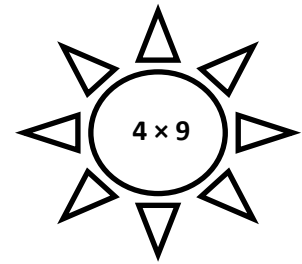
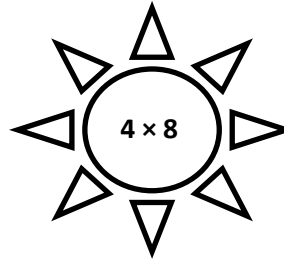
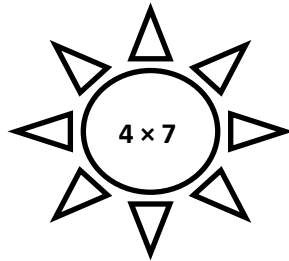
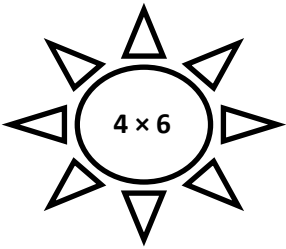

3. The array below shows one strategy for solving 4×9 . Explain the strategy using your own words.

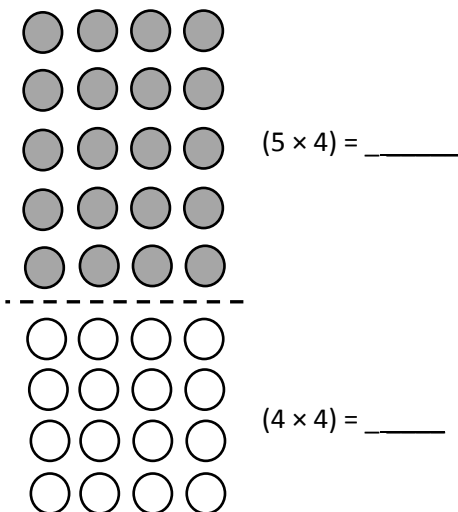

Name _____

Date _____

1. Use the array to complete the related number sentences.

$1 \times 4 = \underline{\quad}$ $\underline{\quad} \div 4 = 1$



$2 \times 4 = \underline{\quad}$ $\underline{\quad} \div 4 = 2$

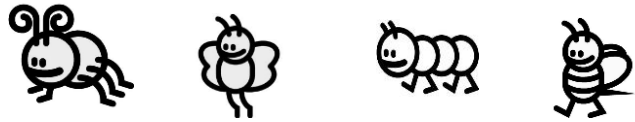

$\underline{\quad} \times 4 = 12$ $12 \div 4 = \underline{\quad}$



$\underline{\quad} \times 4 = 16$ $16 \div 4 = \underline{\quad}$

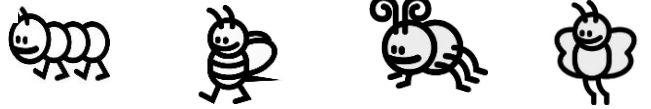

$\underline{\quad} \times \underline{\quad} = 20$ $20 \div \underline{\quad} = \underline{\quad}$



$\underline{\quad} \times \underline{\quad} = 24$ $24 \div \underline{\quad} = \underline{\quad}$

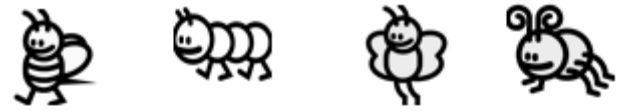

$\underline{\quad} \times 4 = \underline{\quad}$ $\underline{\quad} \div 4 = \underline{\quad}$

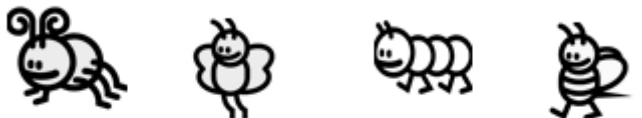

$\underline{\quad} \times 4 = \underline{\quad}$ $\underline{\quad} \div 4 = \underline{\quad}$

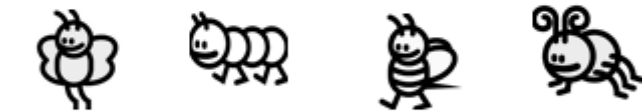

$\underline{\quad} \times \underline{\quad} = \underline{\quad}$ $\underline{\quad} \div \underline{\quad} = \underline{\quad}$

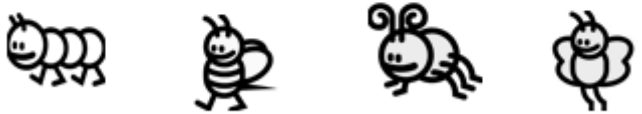

$\underline{\quad} \times \underline{\quad} = \underline{\quad}$ $\underline{\quad} \div \underline{\quad} = \underline{\quad}$

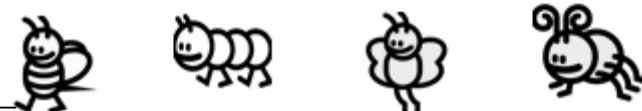

2. The teacher puts 32 students into groups of 4. How many groups does she make? Draw and label a tape diagram to solve.
-
3. The store clerk arranges 24 toothbrushes into 4 equal rows. How many toothbrushes are in each row?
-
4. An art teacher has 40 paint brushes. She divides them equally between her 4 students. She finds 8 more brushes and divides these equally between the students as well. How many brushes does each student receive?

Name _____

Date _____

1. Match.

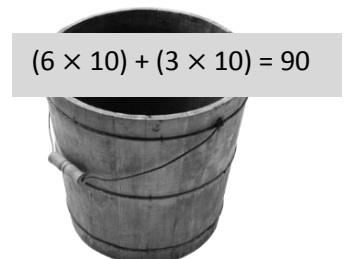
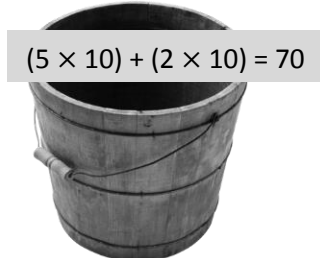
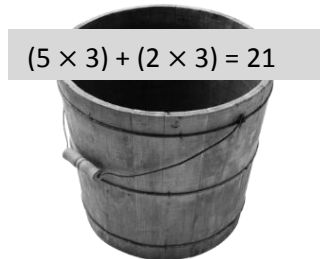
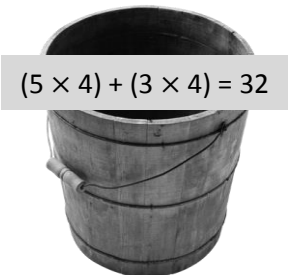
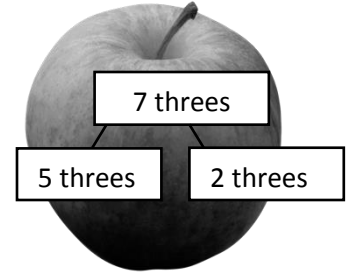
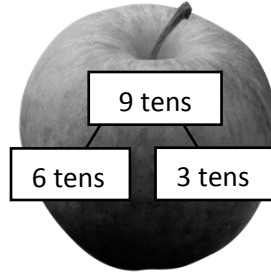
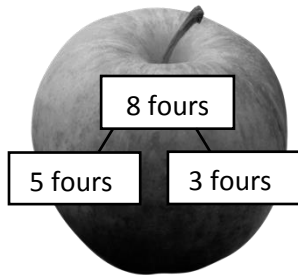
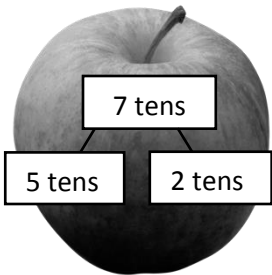

2. $9 \times 4 =$ _____

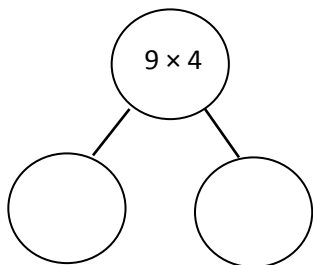

$(\text{ } \times 4) + (\text{ } \times 4) =$

_____ + _____ = _____

$9 \times 4 =$ _____

3. Lydia makes 10 pancakes. She tops each pancake with 4 blueberries. How many blueberries does Lydia use in all?

Lydia uses _____ blueberries in all.

4. Steven solves 7×3 using the distributive property. Show an example of what Steven's work might look like below.

5. There are 7 days in 1 week. How many days are there in 10 weeks?

Name _____

Date _____

1. Label the array. Then complete the equations to make statements that are true.

a. $18 \div 3 = \underline{\quad}$



$(9 \div 3) = 3$

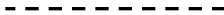

$(9 \div 3) = \underline{\quad}$



$$(18 \div 3) = (9 \div 3) + (9 \div 3)$$

$$= \underline{3} + \underline{\quad}$$

$$= \underline{6}$$

b. $21 \div 3 = \underline{\quad}$



$(15 \div 3) = 5$



$(6 \div 3) = \underline{\quad}$



$$(21 \div 3) = (15 \div 3) + (6 \div 3)$$

$$= \underline{5} + \underline{\quad}$$

$$= \underline{\quad}$$

c. $24 \div 4 = \underline{\quad}$



$(20 \div 4) = \underline{\quad}$

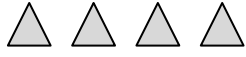

$(4 \div 4) = \underline{\quad}$

$$(24 \div 4) = (20 \div 4) + (\underline{\quad} \div 4)$$

$$= \underline{\quad} + \underline{\quad}$$

$$= \underline{\quad}$$

d. $36 \div 4 = \underline{\quad}$



$(20 \div 4) = \underline{\quad}$

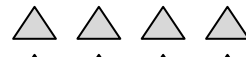

$(16 \div 4) = \underline{\quad}$



$$(36 \div 4) = (\underline{\quad} \div 4) + (\underline{\quad} \div 4)$$

$$= \underline{\quad} + \underline{\quad}$$

$$= \underline{\quad}$$

4. Match equal expressions.

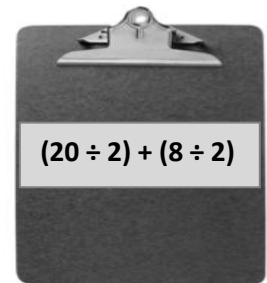
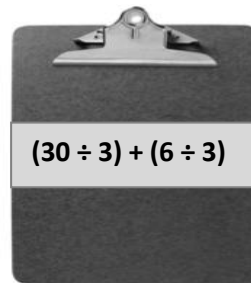
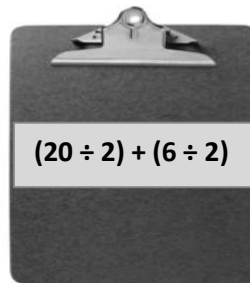
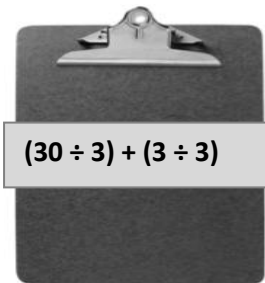
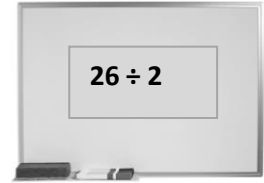
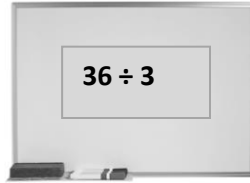

5. Alex draws the array below to find the answer to $35 \div 5$. Explain Alex's strategy.

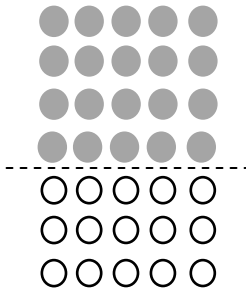

Name _____ Date _____

1. Jerry buys a pack of pencils that costs \$3. David buys 4 sets of markers. Each set of markers also costs \$3.

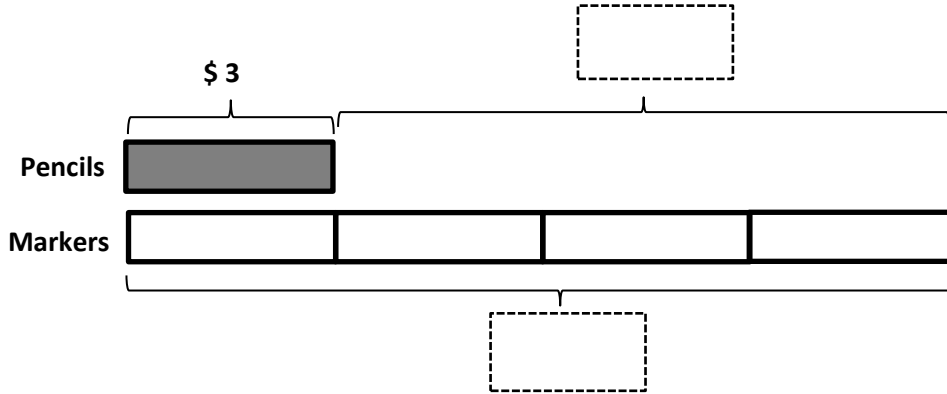

- a. What is the total cost of the markers?

- b. How much more does David spend on 4 sets of markers than Jerry spends on a pack of pencils?

2. Thirty students are eating lunch at 5 tables. Each table has the same number of students.

- a. How many students are sitting at each table?

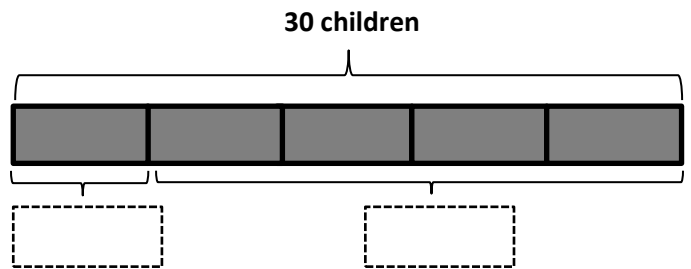

- b. How many students are sitting at 4 tables?

3. The teacher has 12 green stickers and 15 purple stickers. Three super star students are given an equal number of each color sticker. How many green and purple stickers does each student get?

-
4. Three friends go apple picking. They pick 13 apples on Saturday and 14 apples on Sunday. They share the apples equally. How many apples does each person get?

-
5. The store has 28 notebooks in packs of 4. Three packs of notebooks are sold. How many packs of notebooks are left?

Name _____

Date _____

1. Tina eats 8 crackers for a snack each day at school. On Friday she drops 3 and only eats 5. Write and solve an equation to show the total number of crackers Tina eats during the week.

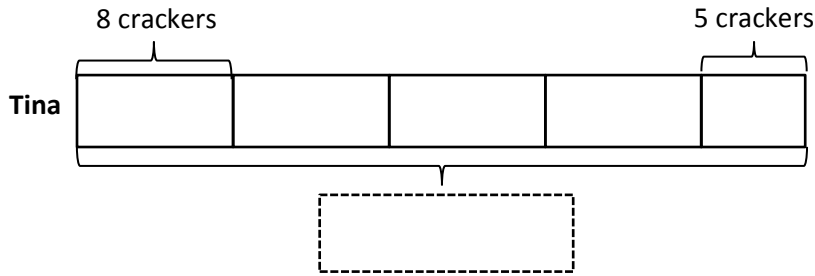

Tina eats _____ crackers.

2. Ballio has a reading goal. He checks 3 boxes of 9 books out from the library. After finishing them, he realizes that he beat his goal by 4 books! Label the tape diagrams to find Ballio's reading goal.

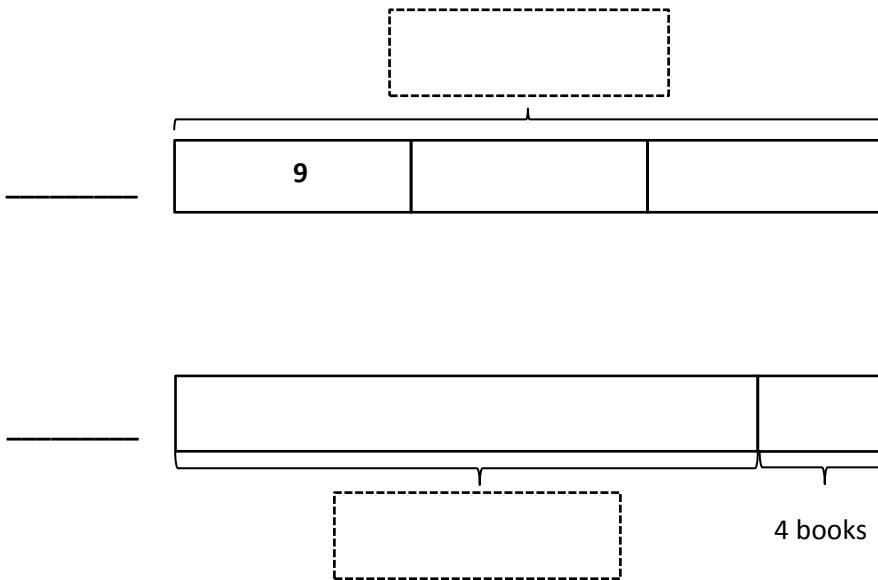

Ballio's goal is to read _____ books.

3. Mr. Nguyen plants 24 trees around the neighborhood pond. He plants equal numbers of Maple, Pine, Spruce, and Birch trees. He waters the Spruce and Birch trees before it gets dark. How many trees does Mr. Nguyen still need to water? Draw and label a tape diagram.

4. Anna buys 24 seeds and plants 3 in each pot. She has 5 pots. How many more pots does Anna need to plant all of her seeds?

Multiply.

$2 \times 1 = \underline{\quad}$ $2 \times 2 = \underline{\quad}$ $2 \times 3 = \underline{\quad}$ $2 \times 4 = \underline{\quad}$

$2 \times 5 = \underline{\quad}$ $2 \times 1 = \underline{\quad}$ $2 \times 2 = \underline{\quad}$ $2 \times 1 = \underline{\quad}$

$2 \times 3 = \underline{\quad}$ $2 \times 1 = \underline{\quad}$ $2 \times 4 = \underline{\quad}$ $2 \times 1 = \underline{\quad}$

$2 \times 5 = \underline{\quad}$ $2 \times 1 = \underline{\quad}$ $2 \times 2 = \underline{\quad}$ $2 \times 3 = \underline{\quad}$

$2 \times 2 = \underline{\quad}$ $2 \times 4 = \underline{\quad}$ $2 \times 2 = \underline{\quad}$ $2 \times 5 = \underline{\quad}$

$2 \times 2 = \underline{\quad}$ $2 \times 1 = \underline{\quad}$ $2 \times 2 = \underline{\quad}$ $2 \times 3 = \underline{\quad}$

$2 \times 1 = \underline{\quad}$ $2 \times 3 = \underline{\quad}$ $2 \times 2 = \underline{\quad}$ $2 \times 3 = \underline{\quad}$

$2 \times 4 = \underline{\quad}$ $2 \times 3 = \underline{\quad}$ $2 \times 5 = \underline{\quad}$ $2 \times 3 = \underline{\quad}$

$2 \times 4 = \underline{\quad}$ $2 \times 1 = \underline{\quad}$ $2 \times 4 = \underline{\quad}$ $2 \times 2 = \underline{\quad}$

$2 \times 4 = \underline{\quad}$ $2 \times 3 = \underline{\quad}$ $2 \times 4 = \underline{\quad}$ $2 \times 5 = \underline{\quad}$

$2 \times 4 = \underline{\quad}$ $2 \times 5 = \underline{\quad}$ $2 \times 1 = \underline{\quad}$ $2 \times 5 = \underline{\quad}$

$2 \times 2 = \underline{\quad}$ $2 \times 5 = \underline{\quad}$ $2 \times 3 = \underline{\quad}$ $2 \times 5 = \underline{\quad}$

$2 \times 4 = \underline{\quad}$ $2 \times 2 = \underline{\quad}$ $2 \times 4 = \underline{\quad}$ $2 \times 3 = \underline{\quad}$

$2 \times 5 = \underline{\quad}$ $2 \times 3 = \underline{\quad}$ $2 \times 2 = \underline{\quad}$ $2 \times 4 = \underline{\quad}$

$2 \times 3 = \underline{\quad}$ $2 \times 5 = \underline{\quad}$ $2 \times 2 = \underline{\quad}$ $2 \times 4 = \underline{\quad}$

Multiply.

$2 \times 1 = \underline{\quad}$ $2 \times 2 = \underline{\quad}$ $2 \times 3 = \underline{\quad}$ $2 \times 4 = \underline{\quad}$

$2 \times 5 = \underline{\quad}$ $2 \times 6 = \underline{\quad}$ $2 \times 7 = \underline{\quad}$ $2 \times 8 = \underline{\quad}$

$2 \times 9 = \underline{\quad}$ $2 \times 10 = \underline{\quad}$ $2 \times 5 = \underline{\quad}$ $2 \times 6 = \underline{\quad}$

$2 \times 5 = \underline{\quad}$ $2 \times 7 = \underline{\quad}$ $2 \times 5 = \underline{\quad}$ $2 \times 8 = \underline{\quad}$

$2 \times 5 = \underline{\quad}$ $2 \times 9 = \underline{\quad}$ $2 \times 5 = \underline{\quad}$ $2 \times 10 = \underline{\quad}$

$2 \times 6 = \underline{\quad}$ $2 \times 5 = \underline{\quad}$ $2 \times 6 = \underline{\quad}$ $2 \times 7 = \underline{\quad}$

$2 \times 6 = \underline{\quad}$ $2 \times 8 = \underline{\quad}$ $2 \times 6 = \underline{\quad}$ $2 \times 9 = \underline{\quad}$

$2 \times 6 = \underline{\quad}$ $2 \times 7 = \underline{\quad}$ $2 \times 6 = \underline{\quad}$ $2 \times 7 = \underline{\quad}$

$2 \times 8 = \underline{\quad}$ $2 \times 7 = \underline{\quad}$ $2 \times 9 = \underline{\quad}$ $2 \times 7 = \underline{\quad}$

$2 \times 8 = \underline{\quad}$ $2 \times 6 = \underline{\quad}$ $2 \times 8 = \underline{\quad}$ $2 \times 7 = \underline{\quad}$

$2 \times 8 = \underline{\quad}$ $2 \times 9 = \underline{\quad}$ $2 \times 9 = \underline{\quad}$ $2 \times 6 = \underline{\quad}$

$2 \times 9 = \underline{\quad}$ $2 \times 7 = \underline{\quad}$ $2 \times 9 = \underline{\quad}$ $2 \times 8 = \underline{\quad}$

$2 \times 9 = \underline{\quad}$ $2 \times 8 = \underline{\quad}$ $2 \times 6 = \underline{\quad}$ $2 \times 9 = \underline{\quad}$

$2 \times 7 = \underline{\quad}$ $2 \times 9 = \underline{\quad}$ $2 \times 6 = \underline{\quad}$ $2 \times 8 = \underline{\quad}$

$2 \times 9 = \underline{\quad}$ $2 \times 7 = \underline{\quad}$ $2 \times 6 = \underline{\quad}$ $2 \times 8 = \underline{\quad}$

Multiply.

$3 \times 1 = \underline{\quad}$ $3 \times 2 = \underline{\quad}$ $3 \times 3 = \underline{\quad}$ $3 \times 4 = \underline{\quad}$

$3 \times 5 = \underline{\quad}$ $3 \times 1 = \underline{\quad}$ $3 \times 2 = \underline{\quad}$ $3 \times 1 = \underline{\quad}$

$3 \times 3 = \underline{\quad}$ $3 \times 1 = \underline{\quad}$ $3 \times 4 = \underline{\quad}$ $3 \times 1 = \underline{\quad}$

$3 \times 5 = \underline{\quad}$ $3 \times 1 = \underline{\quad}$ $3 \times 2 = \underline{\quad}$ $3 \times 3 = \underline{\quad}$

$3 \times 2 = \underline{\quad}$ $3 \times 4 = \underline{\quad}$ $3 \times 2 = \underline{\quad}$ $3 \times 5 = \underline{\quad}$

$3 \times 2 = \underline{\quad}$ $3 \times 1 = \underline{\quad}$ $3 \times 2 = \underline{\quad}$ $3 \times 3 = \underline{\quad}$

$3 \times 1 = \underline{\quad}$ $3 \times 3 = \underline{\quad}$ $3 \times 2 = \underline{\quad}$ $3 \times 3 = \underline{\quad}$

$3 \times 4 = \underline{\quad}$ $3 \times 3 = \underline{\quad}$ $3 \times 5 = \underline{\quad}$ $3 \times 3 = \underline{\quad}$

$3 \times 4 = \underline{\quad}$ $3 \times 1 = \underline{\quad}$ $3 \times 4 = \underline{\quad}$ $3 \times 2 = \underline{\quad}$

$3 \times 4 = \underline{\quad}$ $3 \times 3 = \underline{\quad}$ $3 \times 4 = \underline{\quad}$ $3 \times 5 = \underline{\quad}$

$3 \times 4 = \underline{\quad}$ $3 \times 5 = \underline{\quad}$ $3 \times 1 = \underline{\quad}$ $3 \times 5 = \underline{\quad}$

$3 \times 2 = \underline{\quad}$ $3 \times 5 = \underline{\quad}$ $3 \times 3 = \underline{\quad}$ $3 \times 5 = \underline{\quad}$

$3 \times 4 = \underline{\quad}$ $3 \times 2 = \underline{\quad}$ $3 \times 4 = \underline{\quad}$ $3 \times 3 = \underline{\quad}$

$3 \times 5 = \underline{\quad}$ $3 \times 3 = \underline{\quad}$ $3 \times 2 = \underline{\quad}$ $3 \times 4 = \underline{\quad}$

$3 \times 3 = \underline{\quad}$ $3 \times 5 = \underline{\quad}$ $3 \times 2 = \underline{\quad}$ $3 \times 4 = \underline{\quad}$

Multiply.

$3 \times 1 = \underline{\quad}$ $3 \times 2 = \underline{\quad}$ $3 \times 3 = \underline{\quad}$ $3 \times 4 = \underline{\quad}$

$3 \times 5 = \underline{\quad}$ $3 \times 6 = \underline{\quad}$ $3 \times 7 = \underline{\quad}$ $3 \times 8 = \underline{\quad}$

$3 \times 9 = \underline{\quad}$ $3 \times 10 = \underline{\quad}$ $3 \times 5 = \underline{\quad}$ $3 \times 6 = \underline{\quad}$

$3 \times 5 = \underline{\quad}$ $3 \times 7 = \underline{\quad}$ $3 \times 5 = \underline{\quad}$ $3 \times 8 = \underline{\quad}$

$3 \times 5 = \underline{\quad}$ $3 \times 9 = \underline{\quad}$ $3 \times 5 = \underline{\quad}$ $3 \times 10 = \underline{\quad}$

$3 \times 6 = \underline{\quad}$ $3 \times 5 = \underline{\quad}$ $3 \times 6 = \underline{\quad}$ $3 \times 7 = \underline{\quad}$

$3 \times 6 = \underline{\quad}$ $3 \times 8 = \underline{\quad}$ $3 \times 6 = \underline{\quad}$ $3 \times 9 = \underline{\quad}$

$3 \times 6 = \underline{\quad}$ $3 \times 7 = \underline{\quad}$ $3 \times 6 = \underline{\quad}$ $3 \times 7 = \underline{\quad}$

$3 \times 8 = \underline{\quad}$ $3 \times 7 = \underline{\quad}$ $3 \times 9 = \underline{\quad}$ $3 \times 7 = \underline{\quad}$

$3 \times 8 = \underline{\quad}$ $3 \times 6 = \underline{\quad}$ $3 \times 8 = \underline{\quad}$ $3 \times 7 = \underline{\quad}$

$3 \times 8 = \underline{\quad}$ $3 \times 9 = \underline{\quad}$ $3 \times 9 = \underline{\quad}$ $3 \times 6 = \underline{\quad}$

$3 \times 9 = \underline{\quad}$ $3 \times 7 = \underline{\quad}$ $3 \times 9 = \underline{\quad}$ $3 \times 8 = \underline{\quad}$

$3 \times 9 = \underline{\quad}$ $3 \times 8 = \underline{\quad}$ $3 \times 6 = \underline{\quad}$ $3 \times 9 = \underline{\quad}$

$3 \times 7 = \underline{\quad}$ $3 \times 9 = \underline{\quad}$ $3 \times 6 = \underline{\quad}$ $3 \times 8 = \underline{\quad}$

$3 \times 9 = \underline{\quad}$ $3 \times 7 = \underline{\quad}$ $3 \times 6 = \underline{\quad}$ $3 \times 8 = \underline{\quad}$

A

Correct _____

Solve.

1	$2 \times 2 =$		23	$\underline{\quad} \times 2 = 20$	
2	$3 \times 2 =$		24	$\underline{\quad} \times 2 = 4$	
3	$4 \times 2 =$		25	$\underline{\quad} \times 2 = 6$	
4	$5 \times 2 =$		26	$20 \div 2 =$	
5	$1 \times 2 =$		27	$10 \div 2 =$	
6	$4 \div 2 =$		28	$2 \div 2 =$	
7	$6 \div 2 =$		29	$4 \div 2 =$	
8	$10 \div 2 =$		30	$6 \div 2 =$	
9	$2 \div 2 =$		31	$\underline{\quad} \times 2 = 12$	
10	$8 \div 2 =$		32	$\underline{\quad} \times 2 = 14$	
11	$6 \times 2 =$		33	$\underline{\quad} \times 2 = 18$	
12	$7 \times 2 =$		34	$\underline{\quad} \times 2 = 16$	
13	$8 \times 2 =$		35	$14 \div 2 =$	
14	$9 \times 2 =$		36	$18 \div 2 =$	
15	$10 \times 2 =$		37	$12 \div 2 =$	
16	$16 \div 2 =$		38	$16 \div 2 =$	
17	$14 \div 2 =$		39	$11 \times 2 =$	
18	$18 \div 2 =$		40	$22 \div 2 =$	
19	$12 \div 2 =$		41	$12 \times 2 =$	
20	$20 \div 2 =$		42	$24 \div 2 =$	
21	$\underline{\quad} \times 2 = 10$		43	$14 \times 2 =$	
22	$\underline{\quad} \times 2 = 2$		44	$28 \div 2 =$	

© Bill Davidson

B Improvement _____ # Correct _____

Solve.

1	$1 \times 2 =$		23	$\underline{\quad} \times 2 = 4$	
2	$2 \times 2 =$		24	$\underline{\quad} \times 2 = 20$	
3	$3 \times 2 =$		25	$\underline{\quad} \times 2 = 6$	
4	$4 \times 2 =$		26	$4 \div 2 =$	
5	$5 \times 2 =$		27	$2 \div 2 =$	
6	$6 \div 2 =$		28	$20 \div 2 =$	
7	$4 \div 2 =$		29	$10 \div 2 =$	
8	$8 \div 2 =$		30	$6 \div 2 =$	
9	$2 \div 2 =$		31	$\underline{\quad} \times 2 = 12$	
10	$10 \div 2 =$		32	$\underline{\quad} \times 2 = 16$	
11	$10 \times 2 =$		33	$\underline{\quad} \times 2 = 18$	
12	$6 \times 2 =$		34	$\underline{\quad} \times 2 = 14$	
13	$7 \times 2 =$		35	$16 \div 2 =$	
14	$8 \times 2 =$		36	$18 \div 2 =$	
15	$9 \times 2 =$		37	$12 \div 2 =$	
16	$14 \div 2 =$		38	$14 \div 2 =$	
17	$12 \div 2 =$		39	$11 \times 2 =$	
18	$16 \div 2 =$		40	$22 \div 2 =$	
19	$20 \div 2 =$		41	$12 \times 2 =$	
20	$18 \div 2 =$		42	$24 \div 2 =$	
21	$\underline{\quad} \times 2 = 2$		43	$13 \times 2 =$	
22	$\underline{\quad} \times 2 = 10$		44	$26 \div 2 =$	

© Bill Davidson

A

Correct _____

Solve.

1	$2 \times 3 =$		23	$__ \times 3 = 10$	
2	$3 \times 3 =$		24	$__ \times 3 = 6$	
3	$4 \times 3 =$		25	$__ \times 3 = 9$	
4	$5 \times 3 =$		26	$30 \div 3 =$	
5	$1 \times 3 =$		27	$15 \div 3 =$	
6	$6 \div 3 =$		28	$3 \div 3 =$	
7	$9 \div 3 =$		29	$6 \div 3 =$	
8	$15 \div 3 =$		30	$9 \div 3 =$	
9	$3 \div 3 =$		31	$__ \times 3 = 18$	
10	$12 \div 3 =$		32	$__ \times 3 = 21$	
11	$6 \times 3 =$		33	$__ \times 3 = 27$	
12	$7 \times 3 =$		34	$__ \times 3 = 24$	
13	$8 \times 3 =$		35	$21 \div 3 =$	
14	$9 \times 3 =$		36	$27 \div 3 =$	
15	$10 \times 3 =$		37	$18 \div 3 =$	
16	$24 \div 3 =$		38	$24 \div 3 =$	
17	$21 \div 3 =$		39	$11 \times 3 =$	
18	$27 \div 3 =$		40	$33 \div 3 =$	
19	$18 \div 3 =$		41	$12 \times 3 =$	
20	$30 \div 3 =$		42	$36 \div 3 =$	
21	$__ \times 3 = 15$		43	$13 \times 3 =$	
22	$__ \times 3 = 3$		44	$39 \div 3 =$	

© Bill Davidson

B

Improvement _____

Correct _____

Solve.

1	$1 \times 3 =$		23	$\underline{\quad} \times 3 = 6$	
2	$2 \times 3 =$		24	$\underline{\quad} \times 3 = 30$	
3	$3 \times 3 =$		25	$\underline{\quad} \times 3 = 9$	
4	$4 \times 3 =$		26	$6 \div 3 =$	
5	$5 \times 3 =$		27	$3 \div 3 =$	
6	$9 \div 3 =$		28	$30 \div 3 =$	
7	$6 \div 3 =$		29	$15 \div 3 =$	
8	$12 \div 3 =$		30	$9 \div 3 =$	
9	$3 \div 3 =$		31	$\underline{\quad} \times 3 = 18$	
10	$15 \div 3 =$		32	$\underline{\quad} \times 3 = 24$	
11	$10 \times 3 =$		33	$\underline{\quad} \times 3 = 27$	
12	$6 \times 3 =$		34	$\underline{\quad} \times 3 = 21$	
13	$7 \times 3 =$		35	$24 \div 3 =$	
14	$8 \times 3 =$		36	$27 \div 3 =$	
15	$9 \times 3 =$		37	$18 \div 3 =$	
16	$21 \div 3 =$		38	$21 \div 3 =$	
17	$18 \div 3 =$		39	$11 \times 3 =$	
18	$24 \div 3 =$		40	$33 \div 3 =$	
19	$30 \div 3 =$		41	$12 \times 3 =$	
20	$27 \div 3 =$		42	$36 \div 3 =$	
21	$\underline{\quad} \times 3 = 3$		43	$13 \times 3 =$	
22	$\underline{\quad} \times 3 = 15$		44	$39 \div 3 =$	

© Bill Davidson

Multiply.

$4 \times 1 = \underline{\quad}$ $4 \times 2 = \underline{\quad}$ $4 \times 3 = \underline{\quad}$ $4 \times 4 = \underline{\quad}$

$4 \times 5 = \underline{\quad}$ $4 \times 1 = \underline{\quad}$ $4 \times 2 = \underline{\quad}$ $4 \times 1 = \underline{\quad}$

$4 \times 3 = \underline{\quad}$ $4 \times 1 = \underline{\quad}$ $4 \times 4 = \underline{\quad}$ $4 \times 1 = \underline{\quad}$

$4 \times 5 = \underline{\quad}$ $4 \times 1 = \underline{\quad}$ $4 \times 2 = \underline{\quad}$ $4 \times 3 = \underline{\quad}$

$4 \times 2 = \underline{\quad}$ $4 \times 4 = \underline{\quad}$ $4 \times 2 = \underline{\quad}$ $4 \times 5 = \underline{\quad}$

$4 \times 2 = \underline{\quad}$ $4 \times 1 = \underline{\quad}$ $4 \times 2 = \underline{\quad}$ $4 \times 3 = \underline{\quad}$

$4 \times 1 = \underline{\quad}$ $4 \times 3 = \underline{\quad}$ $4 \times 2 = \underline{\quad}$ $4 \times 3 = \underline{\quad}$

$4 \times 4 = \underline{\quad}$ $4 \times 3 = \underline{\quad}$ $4 \times 5 = \underline{\quad}$ $4 \times 3 = \underline{\quad}$

$4 \times 4 = \underline{\quad}$ $4 \times 1 = \underline{\quad}$ $4 \times 4 = \underline{\quad}$ $4 \times 2 = \underline{\quad}$

$4 \times 4 = \underline{\quad}$ $4 \times 3 = \underline{\quad}$ $4 \times 4 = \underline{\quad}$ $4 \times 5 = \underline{\quad}$

$4 \times 4 = \underline{\quad}$ $4 \times 5 = \underline{\quad}$ $4 \times 1 = \underline{\quad}$ $4 \times 5 = \underline{\quad}$

$4 \times 2 = \underline{\quad}$ $4 \times 5 = \underline{\quad}$ $4 \times 3 = \underline{\quad}$ $4 \times 5 = \underline{\quad}$

$4 \times 4 = \underline{\quad}$ $4 \times 2 = \underline{\quad}$ $4 \times 4 = \underline{\quad}$ $4 \times 3 = \underline{\quad}$

$4 \times 5 = \underline{\quad}$ $4 \times 3 = \underline{\quad}$ $4 \times 2 = \underline{\quad}$ $4 \times 4 = \underline{\quad}$

$4 \times 3 = \underline{\quad}$ $4 \times 5 = \underline{\quad}$ $4 \times 2 = \underline{\quad}$ $4 \times 4 = \underline{\quad}$

© Bill Davidson

Multiply.

$4 \times 1 = \underline{\quad}$ $4 \times 2 = \underline{\quad}$ $4 \times 3 = \underline{\quad}$ $4 \times 4 = \underline{\quad}$

$4 \times 5 = \underline{\quad}$ $4 \times 6 = \underline{\quad}$ $4 \times 7 = \underline{\quad}$ $4 \times 8 = \underline{\quad}$

$4 \times 9 = \underline{\quad}$ $4 \times 10 = \underline{\quad}$ $4 \times 5 = \underline{\quad}$ $4 \times 6 = \underline{\quad}$

$4 \times 5 = \underline{\quad}$ $4 \times 7 = \underline{\quad}$ $4 \times 5 = \underline{\quad}$ $4 \times 8 = \underline{\quad}$

$4 \times 5 = \underline{\quad}$ $4 \times 9 = \underline{\quad}$ $4 \times 5 = \underline{\quad}$ $4 \times 10 = \underline{\quad}$

$4 \times 6 = \underline{\quad}$ $4 \times 5 = \underline{\quad}$ $4 \times 6 = \underline{\quad}$ $4 \times 7 = \underline{\quad}$

$4 \times 6 = \underline{\quad}$ $4 \times 8 = \underline{\quad}$ $4 \times 6 = \underline{\quad}$ $4 \times 9 = \underline{\quad}$

$4 \times 6 = \underline{\quad}$ $4 \times 7 = \underline{\quad}$ $4 \times 6 = \underline{\quad}$ $4 \times 7 = \underline{\quad}$

$4 \times 8 = \underline{\quad}$ $4 \times 7 = \underline{\quad}$ $4 \times 9 = \underline{\quad}$ $4 \times 7 = \underline{\quad}$

$4 \times 8 = \underline{\quad}$ $4 \times 6 = \underline{\quad}$ $4 \times 8 = \underline{\quad}$ $4 \times 7 = \underline{\quad}$

$4 \times 8 = \underline{\quad}$ $4 \times 9 = \underline{\quad}$ $4 \times 9 = \underline{\quad}$ $4 \times 6 = \underline{\quad}$

$4 \times 9 = \underline{\quad}$ $4 \times 7 = \underline{\quad}$ $4 \times 9 = \underline{\quad}$ $4 \times 8 = \underline{\quad}$

$4 \times 9 = \underline{\quad}$ $4 \times 8 = \underline{\quad}$ $4 \times 6 = \underline{\quad}$ $4 \times 9 = \underline{\quad}$

$4 \times 7 = \underline{\quad}$ $4 \times 9 = \underline{\quad}$ $4 \times 6 = \underline{\quad}$ $4 \times 8 = \underline{\quad}$

$4 \times 9 = \underline{\quad}$ $4 \times 7 = \underline{\quad}$ $4 \times 6 = \underline{\quad}$ $4 \times 8 = \underline{\quad}$

© Bill Davidson

A

Correct _____

Multiply or divide.

1	$2 \times 4 =$		23	$\underline{\quad} \times 4 = 40$	
2	$3 \times 4 =$		24	$\underline{\quad} \times 4 = 8$	
3	$4 \times 4 =$		25	$\underline{\quad} \times 4 = 12$	
4	$5 \times 4 =$		26	$40 \div 4 =$	
5	$1 \times 4 =$		27	$20 \div 4 =$	
6	$8 \div 4 =$		28	$4 \div 4 =$	
7	$12 \div 4 =$		29	$8 \div 4 =$	
8	$20 \div 4 =$		30	$12 \div 4 =$	
9	$4 \div 4 =$		31	$\underline{\quad} \times 4 = 24$	
10	$16 \div 4 =$		32	$\underline{\quad} \times 4 = 28$	
11	$6 \times 4 =$		33	$\underline{\quad} \times 4 = 36$	
12	$7 \times 4 =$		34	$\underline{\quad} \times 4 = 32$	
13	$8 \times 4 =$		35	$28 \div 4 =$	
14	$9 \times 4 =$		36	$36 \div 4 =$	
15	$10 \times 4 =$		37	$24 \div 4 =$	
16	$32 \div 4 =$		38	$32 \div 4 =$	
17	$28 \div 4 =$		39	$11 \times 4 =$	
18	$36 \div 4 =$		40	$44 \div 4 =$	
19	$24 \div 4 =$		41	$12 \div 4 =$	
20	$40 \div 4 =$		42	$48 \div 4 =$	
21	$\underline{\quad} \times 4 = 20$		43	$14 \times 4 =$	
22	$\underline{\quad} \times 4 = 4$		44	$56 \div 4 =$	

© Bill Davidson

B

Improvement _____

Correct _____

Multiply or divide.

1	$1 \times 4 =$		23	$\underline{\quad} \times 4 = 8$	
2	$2 \times 4 =$		24	$\underline{\quad} \times 4 = 40$	
3	$3 \times 4 =$		25	$\underline{\quad} \times 4 = 12$	
4	$4 \times 4 =$		26	$8 \div 4 =$	
5	$5 \times 4 =$		27	$4 \div 4 =$	
6	$12 \div 4 =$		28	$40 \div 4 =$	
7	$8 \div 4 =$		29	$20 \div 4 =$	
8	$16 \div 4 =$		30	$12 \div 4 =$	
9	$4 \div 4 =$		31	$\underline{\quad} \times 4 = 12$	
10	$20 \div 4 =$		32	$\underline{\quad} \times 4 = 16$	
11	$10 \times 4 =$		33	$\underline{\quad} \times 4 = 36$	
12	$6 \times 4 =$		34	$\underline{\quad} \times 4 = 28$	
13	$7 \times 4 =$		35	$32 \div 4 =$	
14	$8 \times 4 =$		36	$36 \div 4 =$	
15	$9 \times 4 =$		37	$24 \div 4 =$	
16	$28 \div 4 =$		38	$28 \div 4 =$	
17	$24 \div 4 =$		39	$11 \times 4 =$	
18	$32 \div 4 =$		40	$44 \div 4 =$	
19	$40 \div 4 =$		41	$12 \times 4 =$	
20	$36 \div 4 =$		42	$48 \div 4 =$	
21	$\underline{\quad} \times 4 = 4$		43	$13 \times 4 =$	
22	$\underline{\quad} \times 4 = 20$		44	$52 \div 4 =$	

© Bill Davidson

A

Correct _____

Add or subtract.

1	$0 + 5 =$		23	$10 + 5 =$	
2	$5 + 5 =$		24	$15 + 5 =$	
3	$10 + 5 =$		25	$20 + 5 =$	
4	$15 + 5 =$		26	$25 + 5 =$	
5	$20 + 5 =$		27	$30 + 5 =$	
6	$25 + 5 =$		28	$35 + 5 =$	
7	$30 + 5 =$		29	$40 + 5 =$	
8	$35 + 5 =$		30	$45 + 5 =$	
9	$40 + 5 =$		31	$0 + 50 =$	
10	$45 + 5 =$		32	$50 + 50 =$	
11	$50 - 5 =$		33	$50 + 5 =$	
12	$45 - 5 =$		34	$55 + 5 =$	
13	$40 - 5 =$		35	$60 - 5 =$	
14	$35 - 5 =$		36	$55 - 5 =$	
15	$30 - 5 =$		37	$60 + 5 =$	
16	$25 - 5 =$		38	$65 + 5 =$	
17	$20 - 5 =$		39	$70 - 5 =$	
18	$15 - 5 =$		40	$65 - 5 =$	
19	$10 - 5 =$		41	$100 + 50 =$	
20	$5 - 5 =$		42	$150 + 50 =$	
21	$5 + 0 =$		43	$200 - 50 =$	
22	$5 + 5 =$		44	$150 - 50 =$	

© Bill Davidson

B

Improvement _____

Correct _____

Add or subtract.

1	$5 + 0 =$		23	$10 + 5 =$	
2	$5 + 5 =$		24	$15 + 5 =$	
3	$5 + 10 =$		25	$20 + 5 =$	
4	$5 + 15 =$		26	$25 + 5 =$	
5	$5 + 20 =$		27	$30 + 5 =$	
6	$5 + 25 =$		28	$35 + 5 =$	
7	$5 + 30 =$		29	$40 + 5 =$	
8	$5 + 35 =$		30	$45 + 5 =$	
9	$5 + 40 =$		31	$50 + 0$	
10	$5 + 45 =$		32	$50 + 50 =$	
11	$50 - 5 =$		33	$5 + 50 =$	
12	$45 - 5 =$		34	$5 + 55 =$	
13	$40 - 5 =$		35	$60 - 5 =$	
14	$35 - 5 =$		36	$55 - 5 =$	
15	$30 - 5 =$		37	$5 + 60 =$	
16	$25 - 5 =$		38	$5 + 65 =$	
17	$20 - 5 =$		39	$70 - 5 =$	
18	$15 - 5 =$		40	$65 - 5 =$	
19	$10 - 5 =$		41	$50 + 100 =$	
20	$5 - 5 =$		42	$50 + 150 =$	
21	$0 + 5 =$		43	$200 - 50 =$	
22	$5 + 5 =$		44	$150 - 50 =$	

© Bill Davidson

A

Correct _____

Fill-in the blank.

1	0, 5, __		23	35, __, 45	
2	5, 10, __		24	15, __, 25	
3	10, 15, __		25	40, __, 50	
4	15, 20, __		26	25, __, 15	
5	20, 25, __		27	50, __, 40	
6	25, 30, __		28	20, __, 10	
7	30, 35, __		29	45, __, 35	
8	35, 40, __		30	15, __, 5	
9	40, 45, __		31	40, __, 30	
10	50, 45, __		32	10, __, 0	
11	45, 40, __		33	35, __, 25	
12	40, 35, __		34	__, 10, 5	
13	35, 30, __		35	__, 35, 30	
14	30, 25, __		36	__, 15, 10	
15	25, 20, __		37	__, 40, 35	
16	20, 15, __		38	__, 20, 15	
17	15, 10, __		39	__, 45, 40	
18	0, __, 10		40	50, 55, __	
19	25, __, 35		41	45, 50, __	
20	5, __, 15		42	65, __, 55	
21	30, __, 40		43	55, 60, __	
22	10, __, 20		44	60, 65, __	

© Bill Davidson

B

Improvement _____

Correct _____

Fill-in the blank.

1	5, 10, __		23	15, __, 25	
2	10, 15, __		24	35, __, 45	
3	15, 20, __		25	30, __, 20	
4	20, 25, __		26	25, __, 15	
5	25, 30, __		27	50, __, 40	
6	30, 35, __		28	20, __, 10	
7	35, 40, __		29	45, __, 35	
8	40, 45, __		30	15, __, 5	
9	50, 45, __		31	35, __, 25	
10	45, 40, __		32	10, __, 0	
11	40, 35, __		33	35, __, 25	
12	35, 30, __		34	__, 15, 10	
13	30, 25, __		35	__, 40, 35	
14	25, 20, __		36	__, 20, 15	
15	20, 15, __		37	__, 45, 40	
16	15, 10, __		38	__, 10, 5	
17	0, __, 10		39	__, 35, 30	
18	25, __, 35		40	45, 50, __	
19	5, __, 15		41	50, 55, __	
20	30, __, 40		42	55, 60, __	
21	10, __, 20		43	65, __, 55	
22	35, __, 45		44	__, 60, 55	

© Bill Davidson

Multiply.

$5 \times 1 = \underline{\quad}$ $5 \times 2 = \underline{\quad}$ $5 \times 3 = \underline{\quad}$ $5 \times 4 = \underline{\quad}$

$5 \times 5 = \underline{\quad}$ $5 \times 1 = \underline{\quad}$ $5 \times 2 = \underline{\quad}$ $5 \times 1 = \underline{\quad}$

$5 \times 3 = \underline{\quad}$ $5 \times 1 = \underline{\quad}$ $5 \times 4 = \underline{\quad}$ $5 \times 1 = \underline{\quad}$

$5 \times 5 = \underline{\quad}$ $5 \times 1 = \underline{\quad}$ $5 \times 2 = \underline{\quad}$ $5 \times 3 = \underline{\quad}$

$5 \times 2 = \underline{\quad}$ $5 \times 4 = \underline{\quad}$ $5 \times 2 = \underline{\quad}$ $5 \times 5 = \underline{\quad}$

$5 \times 2 = \underline{\quad}$ $5 \times 1 = \underline{\quad}$ $5 \times 2 = \underline{\quad}$ $5 \times 3 = \underline{\quad}$

$5 \times 1 = \underline{\quad}$ $5 \times 3 = \underline{\quad}$ $5 \times 2 = \underline{\quad}$ $5 \times 3 = \underline{\quad}$

$5 \times 4 = \underline{\quad}$ $5 \times 3 = \underline{\quad}$ $5 \times 5 = \underline{\quad}$ $5 \times 3 = \underline{\quad}$

$5 \times 4 = \underline{\quad}$ $5 \times 1 = \underline{\quad}$ $5 \times 4 = \underline{\quad}$ $5 \times 2 = \underline{\quad}$

$5 \times 4 = \underline{\quad}$ $5 \times 3 = \underline{\quad}$ $5 \times 4 = \underline{\quad}$ $5 \times 5 = \underline{\quad}$

$5 \times 4 = \underline{\quad}$ $5 \times 5 = \underline{\quad}$ $5 \times 1 = \underline{\quad}$ $5 \times 5 = \underline{\quad}$

$5 \times 2 = \underline{\quad}$ $5 \times 5 = \underline{\quad}$ $5 \times 3 = \underline{\quad}$ $5 \times 5 = \underline{\quad}$

$5 \times 4 = \underline{\quad}$ $5 \times 2 = \underline{\quad}$ $5 \times 4 = \underline{\quad}$ $5 \times 3 = \underline{\quad}$

$5 \times 5 = \underline{\quad}$ $5 \times 3 = \underline{\quad}$ $5 \times 2 = \underline{\quad}$ $5 \times 4 = \underline{\quad}$

$5 \times 3 = \underline{\quad}$ $5 \times 5 = \underline{\quad}$ $5 \times 2 = \underline{\quad}$ $5 \times 4 = \underline{\quad}$